

Electronics Module

Rivo™ I Municipal/Industrial

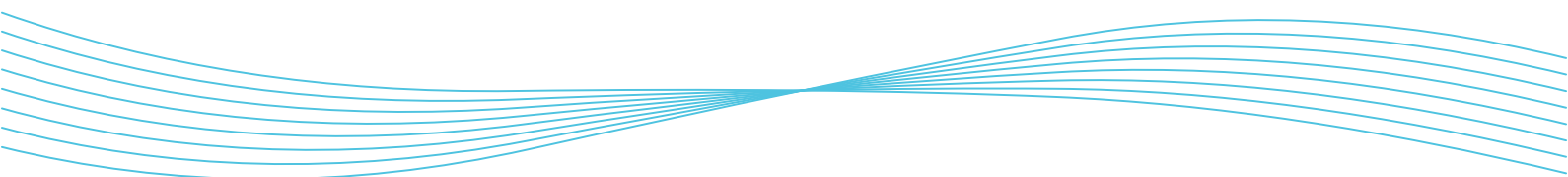

NOTICE

Electronics Module Rivo™ | Municipal/Industrial as of version 1.02

In some countries, RIVO, DEPOLOX, Varia Sens and Wallace & Tiernan are trademarks of Evoqua, its subsidiaries or affiliated companies.

No part of this document may be reproduced in any form (printed, photocopy, microfilm, or any other procedure) or saved, processed, copied, or distributed using electronic data systems - without the express prior written consent of Evoqua Water Technologies GmbH.

All information in this document is considered reliable and corresponds to the generally applicable technical standards. Evoqua assumes no responsibility for the completeness of this information. Users are responsible for making sure that the product is suitable for specific applications. Evoqua assumes no liability for specific or indirect damage or consequential damage arising from the sale, resale or misuse of its products.

1	General notes5	2.9	Safety instructions for specific operating phases 19
1.1	General precept of non-discrimination 5	2.10	Warranty conditions 20
1.2	Target groups 5	2.11	Liability for defects 20
1.3	Information in the instruction manual 6	3	Delivery, Transport and Storage 21
1.4	Associated documents 6	3.1	Checking incoming goods 21
1.5	Retention of the documentation 6	3.2	Packaging 21
1.6	Associated documents 6	3.3	Scope of delivery 21
1.7	New functions and firmware updates 7	3.4	Required components 22
1.8	Digital instruction manual 7	3.4.1	Flow-through adapters 22
1.9	Warnings on the device 7	3.4.2	Sensors 23
1.10	Device Id/type plate 7	3.4.3	Rivo™ Flex Mod Modules 23
1.11	Important System Information - Recovery Key - 8	3.4.4	Modules and Sensor Kits 23
1.12	Warnings and safety instructions 10	3.4.5	Output modules 24
1.13	Notes and information 11	3.4.6	Expansion board for installation on the HMI .. 24
1.14	Design features 11	3.4.7	Impedance converter 24
2	Safety12	3.4.8	Plug-cable combination for sensor 24
2.1	Intended use 13	3.5	Transport..... 25
2.2	Improper use 14	3.6	Storage 25
2.3	General safety instructions 15	4	Technical Data 26
2.4	Personnel qualification 16	4.1	Electronics Module 26
2.5	Spare parts/components 18	4.2	Rivo™ Flex Mod Output modules 29
2.6	Extensions and modifications 18	4.3	Rivo™ Flex Mod Measuring Modules (optional) 31
2.7	Electrical power 18	4.4	Rivo™ Com-Board 485 (optional) 37
2.8	IT security 18		

5	Design	38	7.5	Control parameters	69
5.1	Rivo™ Backboard 4 (Basic housing)	38	7.6	Display of dosing quantity	76
5.2	HMI (housing cover).....	39	7.7	Digital inputs DI 1 and DI 2	76
6	Description	40	7.8	Sample water monitoring	77
6.1	General	40	7.9	mA inputs, Rivo™ Backboard 4	78
6.2	Configuration options	41	7.10	Connections to visualization systems	78
6.2.1	Electronics Module and Flow-through Adapter.....	41	7.11	Controller outputs.....	79
6.2.2	Electronics Module with Rivo™ Flex Mod Modules.....	42	7.11.1	Positioner (with feedback).....	79
7	Function	43	7.11.2	2-point pulse-duration controller for dosing pumps.....	79
7.1	General function.....	43	7.11.3	2-point pulse-frequency controller for solenoid pumps	80
7.2	Areas of application and examples	43	7.11.4	Analog 2-point output.....	80
7.3	Measurement inputs.....	44	7.12	mA outputs	80
7.3.1	Measurement of disinfectants	45	7.13	Positioner feedback	81
7.3.2	pH measurement.....	51	7.14	Digital outputs	81
7.3.3	Redox measurement.....	52	7.15	Relay outputs	82
7.3.4	Fluoride measurement	53	7.16	Messages and alarms.....	83
7.3.5	Conductivity measurement.....	54	7.16.1	Configuration.....	83
7.4	Controller modes (for W3T586961 only)	55	7.16.2	Without Acknowledge.....	84
7.4.1	Ratio control without process measurement ..	56	7.16.3	ACK with reset	84
7.4.2	Ratio control with process measurement	58	7.16.4	Simple ACK.....	84
7.4.3	Single feedback closed-loop control with process measurement.....	60	7.16.5	Safety functions	85
7.4.4	Combination control with process measurement	62	7.17	Status LED states	85
			7.18	Interfaces	86

7.19 USB interface87

7.19.1 Firmware update via USB interface87

7.19.2 RS485 interface (optional)87

7.19.3 Ethernet interface (HMI).....88

8 Installation90

8.1 Requirements with regard to the environment and installation location91

8.1.1 Installation location for drinking water, industrial water and waste water92

8.1.2 Installation site for swimming pool water92

8.2 Installation the device93

8.2.1 Installation with top-hat rail.....93

8.2.2 Installation without top-hat rail (wall installation).....94

8.2.3 Installation drawings.....95

8.3 Removing and fitting the housing cover98

8.4 Installation of Rivo™ Flex Mod Modules98

8.5 Remove the battery insulator100

8.6 Connecting the Ethernet cable.....100

8.7 Electrical installation.....101

8.8 Firmware update via USB interface103

8.9 RS485 interface (optional)104

9 Start-up106

9.1 Initial commissioning and putting back into operation106

10 Shut-down 109

11 OPERATION..... 110

11.1 Display and control elements110

11.1.1 Icons111

11.2 Password protection and user administration113

11.2.1 Login - user administration (user level)113

11.3 Resetting a password.....114

11.4 Application settings115

11.5 Setting operation mode116

11.6 Menu bar116

11.7 System menu117

11.7.1 Acknowledge/Messages128

11.7.2 User log in/log out128

11.8 Service-Center129

11.9 Resetting a password in the Service-Center 131

11.10 Menu field measurement channel132

11.10.1 Measuring channel- Measurement 1.....133

12 Calibration 139

12.1 Temperature calibration139

12.2 Chlorine calibration140

12.3 Membrane sensors calibration141

12.4 pH calibration142

12.5 Redox calibration (mV).....143

12.6 Conductivity calibration144

12.7 Fluoride calibration.....144

13	System messages	146	18	Wiring Diagram	162
14	Troubleshooting	155	19	Marking and approval	174
15	Maintenance	156	19.1	CE mark	174
15.1	Maintenance intervals	156	19.2	UKCA mark	174
15.2	Replace battery	156	20	LICENSE AGREEMENTS	175
15.3	Replacing the fuses on the CPU board	157			
15.4	Cleaning	157			
15.4.1	Cleaning the housing	157			
15.4.2	Cleaning the display	157			
16	Dismantling and disposal	158			
16.1	Dismantling	158			
16.2	Disposal	158			
16.2.1	General information.....	158			
16.2.2	Used electrical/electronic equipment	158			
16.2.3	Used batteries and used storage batteries ..	159			
17	Spare parts, accessories, retrofit kits	160			
17.1	Spare parts.....	160			
17.1.1	Modules for connection to sensors	160			
17.2	Optional accessories	161			

1 GENERAL NOTES

WARNING

Danger in the case of failure to observe the instruction manuals

Possible consequence: fatal or serious injury and significant material damage.

- All persons working with the Rivo™ I Municipal/Industrial Electronics Module (Mod. E10) or the Rivo™ System must have read and understood these instruction manual and the associated manuals.
- This instruction manual is only valid in conjunction with the following instruction manuals:
 - DEPOLOX®-R Flow Cell Module (Mod. D10)
 - DEPOLOX Pool®-R Flow Cell Module (Mod. D10)
 - Varia Sens™ Flow Cell Module (Mod. D10)
 - Flow Sens-R Flow-through Adapter (Mod. D12)
 - Flow Mem-R Flow-through Adapter (Mod. D13)
 - Sensors approved by Evoqua Water Technologies GmbH.
- The warnings and safety instructions must be observed.
- The owner/operator is responsible for ensuring compliance with the relevant accident prevention regulations, other statutory provisions and the accepted rules of safety engineering.

1.1 General precept of non-discrimination

In the interest of better legibility, the linguistic forms male, female and diverse (m/f/d) are not used in parallel in this instruction manual. Nevertheless, all personal nouns and pronouns are understood to apply equally to all genders. We apologize for any inconvenience this may cause.

1.2 Target groups

Only trained and authorized specialist personnel are permitted to work on the Rivo™ I Municipal/Industrial Electronics Module (Mod. E10) or the Rivo™ System. All electrical work (e.g. electrical installation, installation of Rivo™ Flex Modules) must be performed by a qualified electrician. The sections on assembly, installation, start-up, system messages, faults, maintenance, shut-down and dismantling are intended exclusively for trained specialist personnel. Operation, storage, transport and disposal can be carried out by instructed personnel.

1.3 Information in the instruction manual

The Rivo™ System always consists of a Rivo™ I Municipal/Industrial Electronics Module (Mod. E10) with different Rivo™ Flex Modules and an optional Flow Cell Module (Mod. D10) or an optional Flow-through Adapter (Mod. D12 and D13) as well as a sensor.

For clarity, the Rivo™ System is referred to in this instruction manual as the System.

The Rivo™ I Municipal/Industrial (Mod. E10) Electronics Module is referred as the Electronics Module or the device.

The Flow Cell Modules DEPOLOX®-R, DEPOLOX® Pool-R and Varia Sens™ (Mod. D10) are referred as the Flow Cell Module or the Flow-through Adapter or by the product name.

The Flow Sens-R (Mod. D12) and the Flow Mem-R Flow-through Adapter (Mod. D13) are referred as the Flow-through Adapter or by the product name.

The electrode, the 3-electrode single-rod measuring sequence, the combination electrode and the membrane sensor are referred to as the sensor.

Details of the actual equipment may differ from those shown in the illustrations.

1.4 Associated documents

All operating, assembly and installation instructions for assemblies and components as well as Quick Guides must be observed. These manuals are included with the respective assemblies and supplementary components.

1.5 Retention of the documentation

The installation manual form part of the device and must be kept in the immediate vicinity of the device and accessible at all times. The instruction manual must be passed on to third parties with the device.

1.6 Associated documents

All operating, assembly and installation instructions for assemblies and components as well as Quick Guides must be observed. These manuals are included with the respective assemblies and supplementary components.

1.7 New functions and firmware updates

A new firmware version may contain new, enhanced or improved functions that are not yet or not fully described in these instruction manual. The latest version of the instruction manual can be downloaded online at www.evoqua.com.

See the Chapter “Digital Instruction Manual”.

1.8 Digital instruction manual

You can download the digital version of the instruction manual from the official website of Evoqua Water Technologies GmbH.

- Scan the QR code.
- OR enter the following link in your browser:
<https://www.evoqua.com>
Select the corresponding instruction manual and log in.



1.9 Warnings on the device

There is a warning label attached to the device. Read the warnings through carefully. Do not remove this label. If the label is missing or illegible, please contact your contractual partner.

1.10 Device Id/type plate

The type plate is affixed to the device. The type plate identifies the specific device. Please use or state this information if you need service support.

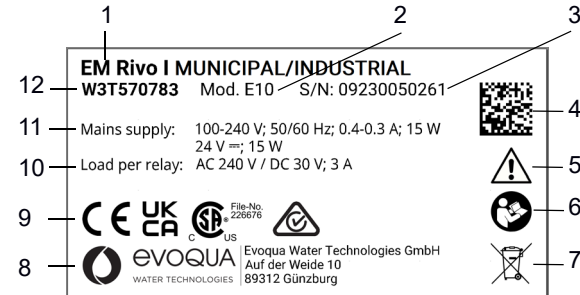

Fig. 1 For example, type plate

- 1 Device name
- 2 Series code/model code (e.g. Mod. E10)
- 3 Sales Order/position/serial number

- 4 DataMatrix code (contains part/serial number)
- 5 Safety information and warnings
- 6 "Read the operating instructions" symbol
- 7 "Disposal" symbol
Disposal instruction: Device must not be disposed of with household waste!
See Chapter "Dismantling and disposal".
- 8 Manufacturer's address
- 9 CE mark (conformity of the device)
UKCA mark (UK Conformity Assessed)
CSA mark (Canadian Standards Association)
Australian approval (RCM - Regulatory Compliance Mark)
- 10 Electrical connection data: Supply voltage and supply output
- 11 Available inputs and outputs: Supply voltage
- 12 Article number

1.11 Important System Information - Recovery Key -

An "Important System Information" label is included in the scope of delivery of the Electronics Module. This is located inside the housing.

The "Important System Information" label contains device-specific data and the access data, such as the App Default for Login User and the Service Default for Login Service-Center, as well as the recovery key for resetting the access data.

The label must be kept in a safe place that is not accessible and protected against unauthorised access.

The access data for the software must be stored securely in accordance with your IT guidelines and must not be handed over to unauthorised persons.

If you lose the recovery key and the user administration access data, please contact your contractual partner.

Recovery Key:

The recovery key is only valid for a specific electronic module and cannot be transferred to other electronics modules. The recovery key is used to reset the user administration if the access data is lost.

Via the Service-Center menu, you can reset the device to the factory settings and delete the customer-specific passwords.

See chapter Operation Service-Center.

App Default:

Access data (user/password) for the initial login of the user.

Service Default:

Access data (user/password) for the initial login in the "Service Center" menu.

See chapter Operation Service-Center.



Abb. 2 Example Recovery Key



- 1 Multilingual notice
- 2 System and serial number
- 3 Ethernet MAC
- 4 App Default
- 5 Service Default
- 6 Code for the Important System Information
- 7 Recovery Key (example)

1.12 Warnings and safety instructions

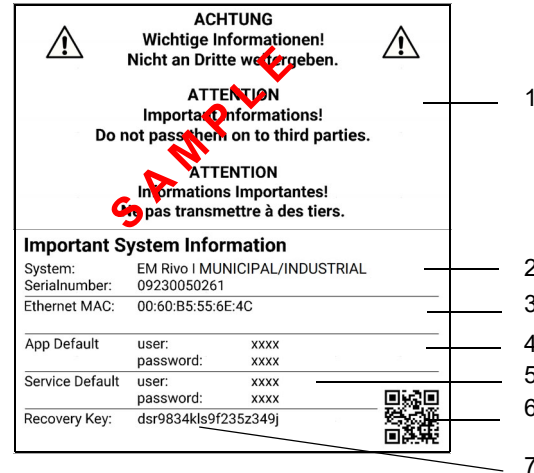

The warnings and safety instructions are classified by means of a signal word and a pictogram. They comprise three parts:



- Nature and source of the danger
- Explanatory notes on nature and source of consequence if the instructions are not complied with
- Where applicable, measure to avoid the danger

 DANGER	
Immediate danger to life and limb	
Failure to comply leads to fatal or serious injury.	

 DANGER	
	Immediate danger caused by electric current
Failure to comply leads to fatal or serious injury.	

 WARNING	
Possible danger	
Failure to comply may lead to fatal or serious injury and to significant material damage.	

 WARNING	
	Danger caused by toxic substances
Failure to comply may lead to fatal or serious injury.	

 WARNING	
	Danger caused by fire or explosive material
Failure to comply may lead to fatal or serious injury.	

 ATTENTION	
Danger with low risk	
Failure to comply may lead to minor injury.	

CAUTION	
Danger with the risk of material damage	
Failure to comply may lead to serious material damage and impair functionality.	

1.13 Notes and information

NOTICE

Notes and information

Supplementary information and notes relevant to a specific topic or goal.



Notes and information



Read the instruction manual.

1.14 Design features

The following representations are used in these operating instructions:

Instructions for action



- 1 Carry out action
- 2 Consequence of action
- 3 Further consequence of action



=> result/goal of the action



List

- List/list item
 - List/list sub-item

2 SAFETY

 DANGER	
	<p>Danger fatal injury caused by electric shock External voltages may still be connected even if the operating voltage is switched off. Possible consequence: fatal or serious injury.</p> <ul style="list-style-type: none"> • All electrical work must be performed by a qualified electrician. • The Electronics module is not equipped with a mains switch and is in operation as soon as the supply voltage is applied. An external switch or circuit breaker with a clearly identifiable “Off” switch position is necessary. • The Electronics module may only be operated with the prescribed supply and control voltage (technical data). • In the event of a fault in the electrical power supply, switch the device off immediately. • Do not carry out work on active parts and equipment to which voltage is applied. • The device operates with liquids. For this reason, DIN EN IEC 62368/60950 must be observed when connecting the devices.

 WARNING	
	<p>Danger caused by uncontrolled dosing and incorrect circulation output If there is a shortage of sample water or the flow rate is too low, if the circulation is switched off or the circulation output is too low, there is a risk of uncontrolled dosing of chemicals. Possible consequence: fatal or serious injury.</p> <ul style="list-style-type: none"> • Never disable the sample water monitoring - even temporarily, e.g. by bridging the signal input. • Chemical dosing must switch off if the circulation is switched off or if the circulation output or flow rate is too low. To ensure this, circulation output or flow rate monitoring must be installed in the system and connected to the electronic module.

 WARNING	
	<p>Risk of injury due to chemicals Dosing liquids are caustic and oxidizing. Possible consequence: fatal or serious injury.</p> <ul style="list-style-type: none">• Observe safety regulations and the prescribed protective clothing for handling chemicals.• All instructions in the product data sheet for the dosing medium must be complied with.

2.1 Intended use

- The Rivo™ I Municipal/Industrial Electronics Module (Mod. E10) must be used exclusively for measuring and controlling the parameters free chlorine, total chlorine, chlorine dioxide, ozone potassium permanganate, pH value, Redox (ORP) voltage, conductivity, fluoride, mA sensors and temperature in water.
- The Electronics Module is part of the Rivo™ System.
- The Electronics Module Rivo™ I Municipal/Industrial may only be operated in combination with the Flow-through Adapter listed below and only sensors approved by Evoqua Water Technologies GmbH may be connected.

Flow-through Adapters:

- Flow Cell Module DEPOLOX®-R (Mod. D10)
- Flow Cell Module DEPOLOX Pool®-R (Mod. D10)
- Flow Cell Module Varia Sens™ (Mod. D10)
- Flow-through Adapter Sens-R (Mod. D12)
- Flow-through Adapter Mem-R (Mod. D13)
- This instruction manual is only valid in conjunction with the instruction manuals for the Flow-through Adapter and the relevant sensors.
- Operational safety can only be guaranteed if the device is used in accordance with its intended purpose.
- The device may only be used for the purpose defined in the contract and under the installation, operating, and environmental conditions specified in this instruction manual.
- No substances may be used other than those described in this instruction manual (chemicals and prescribed calibration chemicals).
- All inspection and maintenance work must be carried out at the specified intervals.

- The system must be protected against access by insufficiently qualified personnel by means of access restriction and the assignment of passwords. Corresponding security concepts must be provided to prevent unauthorized remote access.
- All inspection and maintenance work must be carried out at the specified intervals. Inspections and control measures must be carried out at the prescribed intervals and documented!
- Compliance with the intended use also includes reading this instruction manual and observing all the safety information, instructions and notes therein. The owner/operator of the installation bears sole responsibility for consequences of any use that does not conform with the installation's intended use.

2.2 Improper use

- The Rivo™ I Municipal/Industrial Electronics Module (Mod. E10) must not be used with other Flow-through Adapters than the Rivo™ Series Flow-through Adapters (Mod. D10/D12 and D13).
- The Rivo™ I Municipal/Industrial Electronics Module (Mod. E10) must not be operated with sensors and sensor cables that were not approved by Evoqua Water Technologies GmbH.
- Do not use damaged or obsolete sensors or sensor cables.
- Any use above and beyond the intended use.
- Use that deviates from the information in the technical data.
- Modifications to the device or parts of the device.
- Assembly and installation of or work on electrical components must be carried out by a qualified electrician.
- The Rivo™ System must not be operated with flammable liquids.

2.3 General safety instructions

The manufacturer places great emphasis on safety when working on or with the device. This is already taken into account in the design of the installation and by the integration of safety features.

Safety instructions

This instruction manual describes the safe and proper handling of the device. The specified safety notes and instructions, as well as the local accident prevention regulations and general safety regulations applicable to the area of use, must be observed. Additional industry-wide or in-house safety regulations also continue to apply. The operating company is under obligation to provide operating instructions in accordance with local, national and international specifications, regulations and legislation. Modifications to the device other than those described in this instruction manual are not permissible.

State-of-the-art technology

The unit has been constructed in accordance with state-of-the-art technology and the accepted rules of safety engineering. However, if the unit is used by persons who have not been adequately instructed, danger to the life and limb of such persons or third parties and damage to the unit itself or to other property cannot be ruled out. Work not described in this instruction manual must be performed only by authorized personnel.

2.4 Personnel qualification

 **WARNING**

Danger from unqualified personnel

Possible consequence: fatal or serious injury and significant material damage.

- The company operating the overall system must ensure that only authorized and qualified personnel are permitted to work with and on the device and within their defined scope of authority.
- Unqualified personnel must be kept away from the device.
- The system must be protected against access by insufficiently qualified personnel by means of the assignment of passwords and access restriction.
- Work on electrical components must be carried out by qualified electricians.

It is a prerequisite that all persons assigned to work on or at the device are familiar with and comply with the work safety and accident prevention regulations.

The operating company must train all persons handling the system, device, components, substances etc. and inform them of possible hazards.

It is the responsibility of the operating company to monitor personnel qualification.

If the personnel do not have the necessary knowledge, they must be trained. The responsibilities for work on and with the device (assembly, installation, installation or de-installation of interfaces, operation, troubleshooting, start-up, shut-down, maintenance, dismantling as well as storage, transport and disposal) must be clearly defined and adhered to so that there is no unclear distribution of competencies from the point of view of safety.

Only persons who can be expected to perform their work reliably may work on and with the device. Refrain from any working method that affects the safety of persons, the environment or the device.

Persons who are under the influence of drugs, alcohol or medication affecting their ability to react must not work on or with the device. When selecting personnel, the age- and occupation-specific regulations applicable at the device's place of use must be observed.

The operator must ensure that unauthorized persons are kept at a safe distance from the device.

Personnel are under obligation to immediately report to the operating company any changes that occur in the device that affect safety.

Instructed personnel

Instructed personnel are persons who have received instruction and, where necessary, training on the tasks assigned to them and the associated hazards and have been informed of the necessary protective devices and protective measures.

Trained user

A trained user meets the requirements that apply to an instructed person and in addition, has received system-specific training.

Qualified specialist

Qualified specialist personnel are persons who meet the requirements that apply to a trained user and who, in addition, on the basis of their technical training, knowledge, experience and knowledge of the relevant standards and regulations, are able to assess the work assigned to them and recognize possible hazards. When assessing specialist training, a period of several years' employment in the respective field may also be taken into consideration.

Qualified electrician

Qualified electricians are persons who, on the basis of their technical training, knowledge and experience, as well as knowledge of the relevant standards and regulations, are able to assess the work assigned to them and recognize possible hazards. Qualified electricians must comply with the provisions of the applicable accident prevention regulations.

IT specialist

IT specialists (IT = Information Technology) are persons who, on the basis of their technical training, knowledge and experience, as well as knowledge of the relevant standards and regulations, are able to carry out work on computer systems, networks and network components as well as to independently recognize and avoid possible hazards.

2.5 Spare parts/components

Trouble-free operation of the unit is only guaranteed if original spare parts and components are used in precisely the combination described in this instruction manual. Failure to observe this instruction may lead to malfunctions or damage to the device.

2.6 Extensions and modifications

Never attempt to perform any modifications, extensions or conversions on the device that could impair safety without the written approval of the manufacturer.

2.7 Electrical power

Only qualified electricians or trained personnel supervised by a qualified electrician are permitted to perform any work on electrical components and must do so in accordance with valid electro-technical regulations. During normal operation, the electronic module and the flow-through assembly must remain closed. The electronic module may only be put into operation when the housing is closed, and must be connected to protective earth. Power cables must be connected in accordance with the wiring diagram.

2.8 IT security

The manufacturer offers IT security mechanisms for its products to support secure system operation. We recommend checking on a regular basis to see what information is available regarding IT security developments for your products. Information on this can be found on the Internet. Moreover, for the safe operation of an installation, it is also necessary to integrate the automation components into a holistic IT security concept which comprises the entire system and is in accordance with the state of the art in IT technology. Integrated products from other manufacturers should also be taken into account.

Unsecure connections via the Internet or WLAN are not permitted.

During commissioning of the device, the factory-configured passwords and user names should be replaced with individual ones and the user administration enabled.

2.9 Safety instructions for specific operating phases

- Never employ any working methods which could affect safety!
- All system components must be correctly installed and meet the requirements.
- Only operate the electronic module when the housing is closed.
- The device poses hazards to persons and property. These hazards may arise due to parts carrying voltage or the incorrect dosing of chemicals.
- Only qualified electricians or trained personnel supervised by a qualified electrician are permitted to perform any work on electrical components and must do so in accordance with valid electro-technical regulations.
- Avoid setting up and operating the equipment where there are strong electromagnetic fields. Take appropriate measures to ensure electromagnetic compatibility (EMC) with other devices.
- Inspect the device at least once daily for externally visible damage and faults! Inform the responsible person/authority immediately of any detected changes (including any changes in the operating performance)!
- In the event of malfunctions, switch the device off immediately! Have malfunctions remedied immediately!
- Connect disconnected cables in accordance with the wiring diagram.
- During installation and maintenance work, secure the device against being switched back on!
- If stipulated, disconnect all parts of the device from the power supply before performing any inspection, maintenance or repair work. Then first test the disconnected components to ensure they do not carry any voltage.
- Use only original fuses with the prescribed rating!
- Observe the safety regulations applicable to the device when handling auxiliary materials and chemical substances. Remove leaked auxiliary materials with a suitable binding agent or wipe them up with a cloth. Danger of slipping! Collect auxiliary materials separately and dispose of them appropriately in accordance with the relevant national regulations.
- Never use corrosive cleaning agents (e.g. isopropyl alcohol, spirit, scouring agents) and do not clean using high-pressure steam!

2.10 Warranty conditions

The following must be observed for compliance with warranty conditions. If any of the conditions listed are not met, the warranty is void.

- Assembly, installation, start-up, troubleshooting, maintenance, shut-down and dismantling must be carried out by the manufacturer or qualified specialist personnel, e.g. from contracted companies
- Intended use
- Observation of the operational parameters and settings
- Operation, storage, transport and disposal of the unit must be carried out by qualified specialist personnel or instructed personnel
- Only approved calibration chemicals may be used
- The device must not be exposed to frost or explosive environments.
- The prescribed maintenance work must be carried out
- Use of original spare parts

2.11 Liability for defects

Liability for defects is regulated by the general terms and conditions of supply or by special contractual agreements. To preserve the liability for defects, the operating and environmental conditions, and the operating and maintenance regulations described in this instruction manual must be observed. If they are not observed, the right to claim under liability for defects is rendered invalid.

3 DELIVERY, TRANSPORT AND STORAGE

3.1 Checking incoming goods

- 1 Check transport packaging. Please notify the transport company immediately in the event of damage, as your rights to compensation will otherwise be lost.
- 2 Check that the consignment is complete and undamaged. Pay attention to small parts. If a component is damaged, please contact your contractual partner immediately.

3.2 Packaging

Packaging is reusable waste which must not be disposed of with household waste, but must be collected and disposed of separately, e.g. at public collection points. If necessary, contact your regional or local authorities for details of collection points and options for separating and collecting waste.

3.3 Scope of delivery

Article number	Designation
W3T570783	Rivo™ I Municipal/Industrial Electronics Module (Mod. E10) Analyser
or	
W3T586961	Rivo™ I Municipal/Industrial PC Electronics Module (Mod. E10) Analyser and controll functions
W3T570786	Accessory set EM E10 (incl. PDA pen for touch panels)
W3T173182	Assembly accessories
W3T613933	Instruction Manual, English
--	Label "Important Safety Information" (Recovery Key)

3.4 Required components

NOTICE

Please contact our customer service or visit our online store if you need any spare parts.

3.4.1 Flow-through adapters

Article number	Designation
W3T565860	DEPOLOX®-R Flow Cell Module (Mod. D10) non-pressurised version (3-electrode measuring cell integrated)
W3T566011	DEPOLOX®-R Flow Cell Module (Mod. D10) pressurised version (3-electrode measuring cell integrated)
W3T565858	DEPOLOX® Pool-R Flow Cell Module (Mod. D10) non-pressurised version
W3T565859	DEPOLOX® Pool-R Flow Cell Module (Mod. D10) pressurised version

W3T566012	Varia Sens™-R Flow Cell Module (Mod. D10) non-pressurised version
W3T566013	Varia Sens™-R Flow Cell Module (Mod. D10) pressurised version
W3T159950	Flow Sens-R pH/Redox Y-style Flow-through Adapter (Mod. D12) pressurised version
W3T167442	Flow Sens-R pH/Redox/Fluoride Y-style Flow-through Adapter (Mod. D12) non-pressurised version
W3T158503	Flow Sens-R Conductivity Y-style Flow-through Adapter (Mod. D12) pressurised version
W3T170361	Flow Mem-R Y-style Flow-through Adapter (Mod. D13) non-pressurised version

3.4.2 Sensors

Article number	Designation
W3T160652	3-electrode single-rod measuring sequence Chlorine (platinum version)
W3T160991	3-electrode single-rod measuring sequence Chlorine (gold version)
W3T169297	pH sensor
W3T169298	Redox single-rod measuring sequences (platinum version)
W3T172356	Redox single-rod measuring sequences (gold version)
W3T172052	Conductivity sensor 60 mS or 600 µS
W2T840142	Fluoride sensor
W3T570399	Membrane sensor FC2 M12 (free chlorine)
W3T570400	Membrane sensor CD10.1 (chlorine dioxide)
W3T570451	Membrane sensor OZ10.1 (ozone)
W3T570398	Membrane sensor TC3 M12 (total chlorine)

3.4.3 Rivo™ Flex Mod Modules

Article number	Designation
W3T557878	Rivo™ Flex Mod Dis
W3T557901	Rivo™ Flex Mod mV
W3T557902	Rivo™ Flex Mod pH
W3T557903	Rivo™ Flex Mod Fluoride
W3T557907	Rivo™ Flex Mod Con
W3T557906	Rivo™ Flex Mod 2Al

3.4.4 Modules and Sensor Kits

Article number	Designation
W3T585524	Rivo™ Flex Sens pH Kit
W3T585526	Rivo™ Flex Sens Redox Kit
W3T585527	Rivo™ Flex Sens Redox G Kit
W3T585529	Rivo™ Flex Sens Fluorid Kit
W3T585531	Rivo™ Flex Sens Cond. Muni Kit
W3T585290	Rivo™ Flex Mem TC Kit
W3T585521	Rivo™ Flex Mem FC Kit
W3T585522	Rivo™ Flex Mem CD Kit
W3T585523	Rivo™ Flex Mem OZ Kit
W3T586499	Rivo™ Flex Mem DIS-3E Pt Kit
W3T586500	Rivo™ Flex Mem DIS-3E AU Kit

3.4.5 Output modules

Article number	Designation
W3T557912	Rivo™ Flex Mod 2AO-mA
W3T557914	Rivo™ Flex Mod 2Rel-2DO

3.4.6 Expansion board for installation on the HMI

Article number	Designation
W3T605530	Rivo™ Com-Board 485

3.4.7 Impedance converter

Article number	Designation
W3T165563	Impedance converter

3.4.8 Plug-cable combination for sensor

Article number	Length	Designation Plug-cable combination
W3T164515	5 m	3-electrode single-rod measuring sequence Chlorine
W3T164516	10 m	3-electrode single-rod measuring sequence Chlorine
W3T164547	15 m	3-electrode single-rod measuring sequence Chlorine
W3T164548	30 m	3-electrode single-rod measuring sequence Chlorine
W3T161786	5 m	pH/Redox/Conductivity sensor
W3T161844	10 m	pH/Redox/Conductivity sensor
W3T161883	15 m	pH/Redox/Conductivity sensor
W3T571110	30 m	pH/Redox/Conductivity sensor

3.5 Transport

ATTENTION

Danger due to impact or breakage

Possible consequence: Injury or material damage.

- Follow the instructions and warnings on the packaging.
- Protect the device against impact during transport and transport it in the original packaging. Keep the packaging until the system has been commissioned and put into operation.
- Observe instructions on the packaging for the correct positioning of the device.
- Do not expose the device to shocks, moisture, rain, frost, heat or direct sunlight.
- Observe the specified temperatures for transport and storage (see Technical Data).

3.6 Storage

ATTENTION

Danger caused by incorrect storage

Incorrect storage can impair the functionality of the device.
Possible consequence: Injury or material damage.

- Store the device in dry condition in a dust-free environment and protected against moisture.
- Do not store the device outdoors or expose it to aggressive media, and protect it against direct sunlight and mechanical damage.
- Observe the specified temperatures for storage (see Technical Data).
- Regularly check the general condition of the device and the packaging.

4 TECHNICAL DATA

4.1 Electronics Module

Electronics Module Rivo™ I Municipal/Industrial (Mod. E10)		
Article number	W3T570783 / W3T586961	
Area of application	Potable water, industrial water and processing water, swimming pool water	
Housing	Dimensions (WxHxD)	220 x 305 x 153 mm
	Weight	approx. 3.7 kg
	Protection rating	IP66
	Mains connection	100 ... 240 V AC \pm 10% 50 ... 60 Hz or 24 V DC -15 ... +20 %, 15 W
Display	4.3" graphic color display with backlit LED and resistive touchscreen	
Insulation	Overvoltage category	2
	Contamination level	2
	Protection category	1
Approvals	CE, CSA	
Operating conditions	Ambient temperature	0 ... 50 °C (32 ... 122 °F)
	Relative humidity	< 80 %, non-condensing, moist environment
	Environment	No direct sunlight, use indoors
	Atmospheric pressure	75 ... 106 kPa
	Max. working height (altitude)	2000 m
	Ambient noise	<45 dB

Transport and storage temperature	-20 ... +70 °C (-4 ... 158 °F) Store the device in dry condition in a dust-free environment and protected against moisture. Do not store the device outdoors or expose it to aggressive media, and protect it against direct sunlight and mechanical damage.
Digital inputs (Backboard 4)	<ul style="list-style-type: none"> • 2x for voltage-free contact (internal 24 V DC power supply) • Freely selectable function in menu • When input open: DI active • When input closed: DI inactive
Measurement inputs (Backboard 4)	• 1x temperature input PT 1000 (0 ... 100 °C/32 ...212 °F)
	<ul style="list-style-type: none"> • 1x positioner position feedback • Positioner position feedback • Potentiometer 1kOhm or 5kOhm, 0 ... 1 V, 0 ... 10 V, 0 ... 20 mA (adjustable via the menu)
	• 1x mA input for flow rate 0 ... 20 mA/4 ... 20 mA (electrically isolated)
	• 1x mA input for external setpoint or dosing factor (electrically isolated) 0 ... 20 mA/4 ... 20 mA
Module slots	• 4x module slot for Rivo™ Flex Mod Modules

4 Technical Data

EN Rivo™ I Municipal/Industrial

Relay outputs (Backboard 4)	Version	<ul style="list-style-type: none"> • 2x changeover contact with integrated fuse, replaceable • Type TR5 3,15 A T
	Nominal breaking capacity	<ul style="list-style-type: none"> • 3A 250V AC, 1250VA max. (resistive load) • 1A 250V AC, 250VA max. ($\cos \phi = 0.4$) • 3A 30V DC, 150W max. (resistive load)
	Max. switching voltage	<ul style="list-style-type: none"> • 250V AC / 30V DC
	UL/CSA rating	<ul style="list-style-type: none"> • 3A, 125/250V AC (general use) • 3A 30V DC (resistive)
NOTICE		
<p>When connecting inductive or capacitive loads (e.g. pump with integrated switching power supply), an additional power relay with suitable specification must be provided. Each relay output has an integrated 3.15 A fuse as overcurrent protection.</p> <p>Typical use of the relay: Enabling contact for external alarm or activation of the dosing devices or dosing pumps. If the relay is used to switch inductive loads with direct voltage, the load must be equipped with a suppressor circuit against overvoltage (free-wheeling diode etc.).</p>		
Interface (only if Rivo™ Com Board 485 is used)	<ul style="list-style-type: none"> • RS485 interface with Wallace & Tiernan protocol for connection to OPC server or control system for data visualization 	

4.2 Rivo™ Flex Mod Output modules

Rivo™ Flex Mod 2AO-mA	
Article number	W3T557912
Description	mA signal output module, 2-channel
Analog outputs (only if Rivo™ Flex Mod 2AO-mA is used)	<ul style="list-style-type: none">• 2-way mA output module 0/4 to 20 mA• Freely configurable signal assignment via menu• Load max. 500 ohm, accuracy < 0.5 % FS• Integrated load monitoring• Galv. isolated up to 50 V relative to earth

Rivo™ Flex Mod 2 Rel-2DO		
Article number	W3T557914	
Description	Relay module for activation of dosing outputs and alarms	
Relay outputs (only if Rivo™ Flex Mod 2 Rel-2DO is used)	Version	<ul style="list-style-type: none"> • 2x changeover contact with integrated fuse (5 A, not replaceable)
	Nominal breaking capacity	<ul style="list-style-type: none"> • 3A 250V AC, 1250VA max. (resistive load) • 1A 250V AC, 250VA max. (cos φ = 0.4) • 3A 30V DC, 150W max. (resistive load)
	Max. switching voltage	<ul style="list-style-type: none"> • 250V AC / 30V DC
	Max. switching current	<ul style="list-style-type: none"> •
	UL/CSA rating	<ul style="list-style-type: none"> • 3A, 125/250V AC (general use) • 3A 30V DC (resistive)
NOTICE		
<p>When connecting inductive or capacitive loads (e.g. pump with integrated switching power supply), an additional power relay with suitable specification must be provided. Each relay output has an integrated 5 A fuse as overcurrent protection.</p> <p>Typical use of the relay: Enabling contact for external alarm or activation of the dosing devices or dosing pumps.</p>		
Digital outputs (only if Rivo™ Flex Mod 2Rel-2DO is used)	<ul style="list-style-type: none"> • Optocoupler output for connection of enabling inputs to dosing systems, dosing pumps, electrolysis systems • Max. ext. power supply 24 V DC • max. current 20 mA 	

4.3 Rivo™ Flex Mod Measuring Modules (optional)

Rivo™ Flex Mod Dis	
Article number	W3T557878
Description	Measuring module to measure disinfectants with DEPOLOX®-R, DEPOLOX® Pool-R and membrane sensors
Dimensions	65 x 23 x 71 mm (LxWxD)
Ambient temperature	0 ... +70 °C (32 ... 158 °F)
Storage temperature	-20 ... +70 °C (-4 ... 158 °F)
Measuring input	
Sensor type	<ul style="list-style-type: none"> • 3-electrode sensor • Membrane covered sensors
Measuring principle	Potentiostatic amperometry
Temperature drift	< 0.5 % / 10 k
Linearity error	< 0.1 % FS
Calibration	Pre-calibrated
Cell voltage U _{pot} 3-electrode sensor	-2000 ... +2000 mV
Cell voltage U _{pot} Membrane covered sensors	0 ... 10 V
Input signal	-10 µA ... +1000 µA
Measuring ranges	10 µA / 100 µA / 1000 µA

Rivo™ Flex Mod mV	
Article number	W3T557901
Description	Measuring module to measure Redox value
Dimensions	65 x 23 x 71 mm (LxWxD)
Ambient temperature	0 ... + 70 °C (32 ... 158 °F)
Storage temperature	-20 ... +70 °C (-4 ... 158 °F)
Measuring input	
Sensor type	Redox single-rod measuring electrode
Measuring principle	mV voltage measurement
Temperature drift	< 0.1 % / 10 k
Calibration	Pre-calibrated
Input signal	-1500 mV ... +1500 mV
Measuring ranges	-1500 ... +1500 mV
Input impedance	>10 ¹² ohms

Rivo™ Flex Mod pH	
Article number	W3T557902
Description	Measuring module to measure pH value
Dimensions	65 x 23 x 71 mm (LxWxD)
Ambient temperature	0 ... + 70 °C (32 ... 158 °F)
Storage temperature	-20 ... +70 °C (-4 ... 158 °F)
Measuring input	
Sensor type	pH single-rod measuring electrode
Measuring principle	pH voltage measurement
Temperature drift	< 0.1% / 10 k
Calibration	Pre-calibrated
Input signal	-900 ... +900 mV
Measuring ranges	pH 0.00 ... pH 14.00
Input impedance	>10 ¹² Ohm

Rivo™ Flex Mod Fluoride	
Article number	W3T557903
Description	Measuring module to measure fluoride value
Dimensions	65 x 23 x 71 mm (LxWxD)
Ambient temperature	0 ... + 70 °C (32 ... 158 °F)
Storage temperature	-20 ... +70 °C (-4 ... 158 °F)
Measuring input	
Sensor type	Fluoride electrode
Measuring principle	mV voltage measurement
Temperature drift	< 0.1 % / 10 k
Calibration	Pre-calibrated
Input signal	-200 ... +200 mV
Measuring ranges	0.2 ... 20 mg/l
Input impedance	>10 ¹² Ohm

Rivo™ Flex Mod Con	
Article number	W3T557907
Description	Measuring module to measure conductivity
Dimensions	65 x 23 x 71 mm (LxWxD)
Ambient temperature	0 ... + 70 °C (32 ... 158 °F)
Storage temperature	-20 ... +70 °C (-4 ... 158 °F)
Measuring input	
Sensor type	LF325
Measuring principle	Conductive, 4 electrodes
Temperature measurement	NTC
Temperature measuring range	0 ... 100 °C/32 ... 212 °F
Temperature drift	< 0.5 % / 10 k
Calibration	Pre-calibrated
Cell voltage	0 ... 5V AC RMS
Cell current	0 ... 20 mA AC RMS
Measuring range	10 µS/cm ... 300 mS/cm

Rivo™ Flex Mod 2AI	
Article number	W3T557906
Description	Measuring module for measuring two sensors or input signals with mA or V measuring signal
Dimensions	65 x 23 x 71 mm (LxWxD)
Ambient temperature	0 ... +70 °C (32 ... 158 °F)
Storage temperature	-20 ... +70 °C (-4 ... 158 °F)
Measuring input 1/2	
Sensor type	0/4 ... 20 mA active 4 ... 20 mA passive 0 ... 10 V active
Measuring principle	mA current measurement voltage measurement
Temperature drift	< 0.25 % / 10 k
Calibration	Pre-calibrated
Input signal	0/4 ... 20 mA scalable or 0 ... 10 V
DC output	24 V / 25 mA max.
Input resistance	mA: <100 Ohm V: >1 MOhm

4.4 Rivo™ Com-Board 485 (optional)

Rivo™ Com-Board 485	
Article number	W3T583003
Interface	RS485 interface with Wallace & Tiernan protocol for connection to OPC server or control system for data visualization

5 DESIGN

5.1 Rivo™ Backboard 4 (Basic housing)

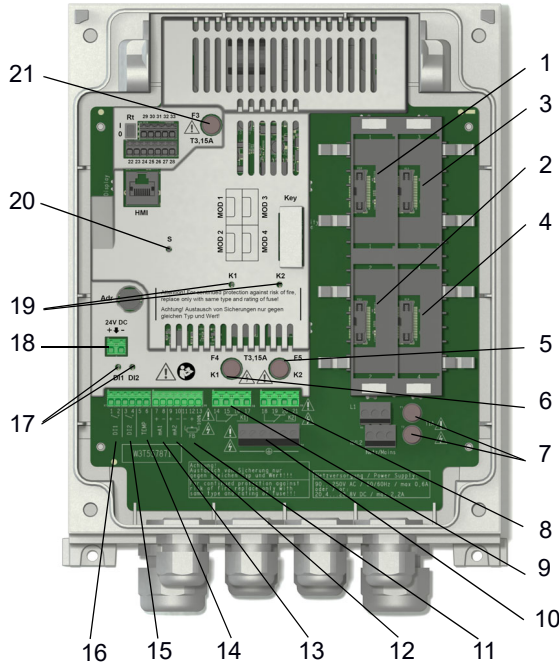

NOTICE

Module configuration see chapter Installation Rivo™ Flex Mod Measuring Modules.
Observe assignment of the module slots (sequence).
Status LEDs of the Rivo™ Flex Mod Modules see chapter Function - Status LEDs.

- 1 Module slot for Rivo™ Flex Mod - MOD 1 (measuring module)
- 2 Module slot for Rivo™ Flex Mod - MOD 2 (measuring module)
- 3 Module slot for Rivo™ Flex Mod - MOD 3 (relay module)
- 4 Module slot for Rivo™ Flex Mod - MOD 4 (mA output module)
- 5 Fuse for relay 2
- 6 Fuse for relays 1
- 7 Mains fuses
- 8 Terminals for relay 2
- 9 Terminals for relay 1
- 10 PE connection terminals
- 11 Feedback input for actuator
- 12 mA input 2
- 13 mA input 1
- 14 Temperature input
- 15 Digital input 2
- 16 Digital input 1
- 17 Status LEDs of the digital inputs
- 18 24V DC connector
- 19 Status LED of relays K1/K2
- 20 Status LED
- 21 24V DC internal fuse

5.2 HMI (housing cover)

NOTICE

Figure shows the HMI including optional expansion board

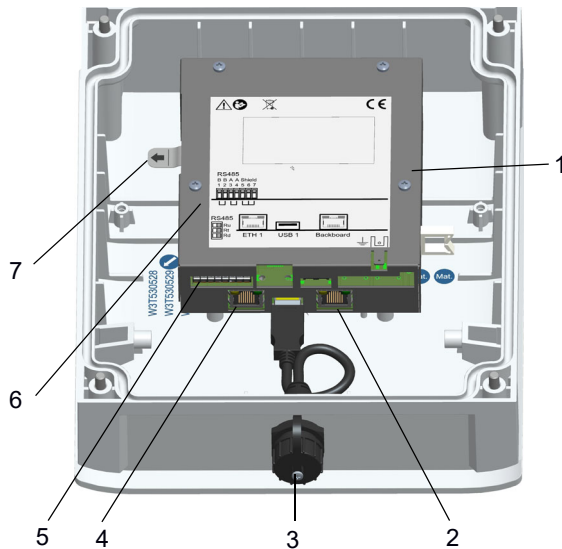

- 1 HMI cover
- 2 Connection to the Backboard 4
- 3 USB 1
- 4 Ethernet 1
- 5 RS485 terminal strip
- 6 RS485 switch bus termination/Symmetry
- 7 Battery Insulator

6 DESCRIPTION

6.1 General

The Rivo™ I Municipal/Industrial Electronics Module (Mod. E10) measures and regulates chemical substances such as chlorine, chlorine dioxide, ozone, potassium permanganate, pH, redox, brine or fluoride, depending on which measuring modules and sensors are fitted.

Depending on the measuring modules installed, the Electronics Module is equipped with up to two measuring inputs at module slots 1 and 2. It also has two additional I/O modules for mA outputs or additional switching outputs.

The Electronics Module is available in two versions. They differ in the controller function provided. Both versions are available as wall-mounted devices.

Article number	Designation
W3T570783	Rivo™ I Municipal/Industrial Electronics Module (Mod. E10) Analyser
or	
W3T586961	Rivo™ I Municipal/Industrial PC Electronics Module (Mod. E10) Analyser and controll functions

6.2 Configuration options

6.2.1 Electronics Module and Flow-through Adapter

Flow-through Adapters	Electronics Module Rivo™ I Municipal/Industrial (Mod. E10)
Flow Cell Module DEPOLOX®-R (Mod. D10) non-pressurised version, article number W3T565860	✓
Flow Cell Module DEPOLOX®-R (Mod. D10) pressurised version, article number W3T566011	✓
Flow Cell Module DEPOLOX® Pool-R (Mod. D10) non-pressurised version, article number W3T565858	✓
Flow Cell Module DEPOLOX® Pool-R (Mod. D10) pressurised version, article number W3T565859	✓
Flow Cell Module Varia Sens™-R (Mod. D10) non-pressurised version, article number W3T566012	✓
Flow Cell Module Varia Sens™-R (Mod. D10) pressurised version, article number W3T566013	✓
Flow-through Adapter Flow Sens-R (Mod. D12) non-pressurised version, article number W3T159950/ W3T167442/W3T158503/W3T170361	✓
Flow-through Adapter Flow Mem-R (Mod. D13) pressurised version, article number W3T566013	✓

6.2.2 Electronics Module with Rivo™ Flex Mod Modules

Module slot 1 (only measuring module)	Module slot 2 (only measuring module)	Module slot 3	Module slot 4
Rivo™ Flex Mod Dis	Rivo™ Flex Mod Dis	Rivo™ Flex Mod 2Rel-2DO	Rivo™ Flex Mod 2AO-mA
Rivo™ Flex Mod mV	Rivo™ Flex Mod mV		
Rivo™ Flex Mod pH	Rivo™ Flex Mod pH		
Rivo™ Flex Mod Fluoride	Rivo™ Flex Mod Fluoride		
Rivo™ Flex Mod Con	Rivo™ Flex Mod Con		
Rivo™ Flex Mod 2AI	Rivo™ Flex Mod 2AI		

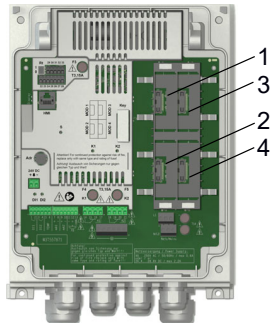

Fig. 3 Inside of module slot

- 1 Module slot 1
- 2 Module slot 2
- 3 Module slot 3
- 4 Module slot 4

7 FUNCTION

7.1 General function

The Electronics Module is used for the measurement and regulation of the following parameters:

- Free chlorine, chlorine dioxide, ozone or potassium permanganate with 3-electrode measuring cell (temperature-compensated)
- Free chlorine, total chlorine and combined chlorine, chlorine dioxide, ozone with membrane sensor (temperature-compensated)
- Conductivity - This measurement is automatically temperature-compensated.
- pH value (temperature-compensated)
- Redox voltage
- Temperature measurement

7.2 Areas of application and examples

Areas of application:

- Drinking water
- Industrial water
- Waste water
- Process water

Application examples:

- Measurement and regulation of chlorine, pH, redox, conductivity, fluoride, total chlorine, chlorine dioxide and ozone
- Measurement and monitoring of water parameters
- Flow-controlled chlorination of drinking water (combination control) - only with Rivo™ Municipal/Industrial (W3T586961)
- Flow-controlled fluoride dosing (combination control) - only with Rivo™ Municipal/Industrial (W3T586961)
- Measurement and regulation of pH-value
- Quantity-proportional dosing of disinfectants (ratio control)
- Measurement and quantity-proportional dosing of chlorine with linearization of the actuator (with positioner)
- Monitoring and raising of alarm if limit values exceeded

EN Rivo™ I Municipal/Industrial

- Data visualization
- Data transfer to higher-level systems
- Optionally, two additional control signal inputs for flow measurement and external setpoint setting can be connected with combination control or ratio control.

NOTICE

To record process measurements (Cl₂, pH, ...) and for flow-controlled dosing of chemicals (ratio control, combination control), the Rivo™ Municipal/Industrial (W3T586961) must be used.

7.3 Measurement inputs**NOTICE**

When the Electronics Module is switched on, the Rivo™ Flex Mod Measuring Modules with which it is fitted must be initialized in the Application bar. Equipment fitted on the Measuring Module must always be initialized via the Application bar.

The following Rivo™ Flex Mod Measuring Modules can be installed at the module slots:

Designation/ Article Number	Measuring module applications
Rivo™ Flex Mod Dis W3T557878	Measurement of disinfectants with DEPOLOX®-R, DEPOLOX® Pool-R and membrane sensors FC2 (free chlorine), CD10.1 (chlorine dioxide), OZ10.1 (ozone), TC3 (total chlorine)
Rivo™ Flex Mod mV W3T557901	Measurement of redox value
Rivo™ Flex Mod pH W3T557902	Measurement of pH value
Rivo™ Flex Mod Fluoride W3T557903	Measurement of fluoride value
Rivo™ Flex Mod 2AI W3T557906	Measurement of sensors with mA or V measuring signal
Rivo™ Flex Mod Con W3T557907	Measurement of conductivity

7.3.1 Measurement of disinfectants

For the measurement of disinfectants with the Rivo™ Municipal/Industrial, various flow modules and sensors can be connected to the Electronics Module:

- 3-electrode measuring cell DEPOLOX®-R
- 3-electrode single-rod measuring cell DEPOLOX® Pool-R
- Membrane sensors

3-electrode measuring cell - DEPOLOX®-R:

Drinking water, service and process water as well as the water in swimming pools is disinfected by adding disinfectants such as chlorine, chlorine dioxide, ozone or potassium permanganate.

The disinfectant content can be measured using the DEPOLOX®-R flow module with integrated 3-electrode measuring cell.

The DEPOLOX®-R flow module can be fitted with further sensors such as pH, redox, fluoride, conductivity sensors or membrane sensors, for example FC2 (free chlorine), CD10.1 (chlorine dioxide), OZ10.1 (ozone) and TC3 (total chlorine).

A Rivo™ Flex Mod Dis Measuring Module is installed for connection of the DEPOLOX®-R flow module to the Electronics Module. Various controller functions are available, depending on the application selected.

Operating principle of the 3-electrode measuring cell - DEPOLOX®-R:

The measuring cell in the DEPOLOX®-R flow cell module is a 3-electrode measuring cell with external potentiostatic control loop.

Working and counter electrode are designed as semi-annular electrodes and made from a special platinum alloy.

A silver-silver chloride electrode connected to the sample water via two diaphragms (membranes) serves as the reference electrode. The reference electrode with PVC mounting is dipped into an electrolyte solution. If necessary, the electrolyte solution can be replenished during operation.

For connection to the Electronics Module, the Rivo™ Flex Mod Dis Measuring Module must be installed in module slot 1 or 2 in the Electronics Module.

Measurement with the 3-electrode measuring cell is pH-value dependent and follows the HOCL characteristic curve.

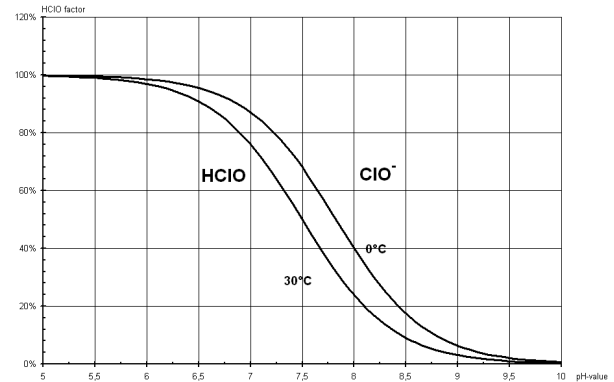

Fig. 4 HOCl characteristic curve

An adjustable cell voltage U_{pot} is output via the potentiostatic control loop between working electrode (red) and reference electrode (white) by connecting the 3-electrode measuring cell to the electronic device (Rivo™ Flex Mod Dis Measuring Module). A cell current (μA signal) proportional to the concentration of disinfectant in the sample water is produced and is then evaluated with the Electronics Module.

A special electrode cleaning sand is poured into the flow module. It circulates with the sample water flow and continually cleans the platinum electrodes.

There is a multi-sensor integrated in the DEPOLOX®-R for temperature measurement and monitoring of the flow rate. The multi-sensor must be connected to the Electronics Module.

3-electrode single-rod chlorine measuring cell - DEPOLOX® Pool-R:

The water in swimming pools is almost exclusively disinfected by adding chlorine.

The free chlorine content can be measured using the DEPOLOX® Pool-R flow module and the 3-electrode single-rod chlorine measuring cell.

The 3-electrode single-rod chlorine measuring cell can only be installed in the DEPOLOX® Pool-R flow module. Its installation guarantees a stable measuring signal.

For connection to the Electronics Module, the Rivo™ Flex Mod Dis Measuring Module must be installed in module slot 1 or 2 in the Electronics Module.

Operating principle of the 3-electrode single-rod chlorine measuring cell - DEPOLOX® Pool-R:

The 3-electrode single-rod chlorine measuring cell is maintenance-free and has a service life of approx. two years. A special electrode cleaning sand is poured into the DEPOLOX® Pool-R flow module and is swirled around the glass electrodes, thus continually cleaning them. The electrode cleaning sand must be replaced regularly. The interval for replacement depends on the sample water (contamination level).

Measurement with the 3-electrode single-rod chlorine measuring cell is pH-value dependent and follows the HOCl characteristic curve.

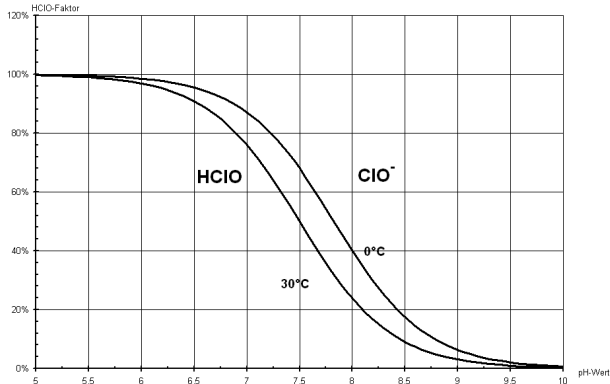

Fig. 5 HOCl characteristic curve

There is a multi-sensor integrated in the DEPOLOX® Pool-R flow module for temperature measurement and monitoring of the flow rate. The multi-sensor must be connected to the Electronics Module.

Membrane sensors

Membrane sensors can also be used to measure disinfectants in the water. These membrane sensors are available in different versions for the measurement of free chlorine, chlorine dioxide, ozone or total chlorine. The membrane sensors are installed in the flow modules, for example, the DEPOLOX®-R or Varia Sens™-R.

For connection to the Electronics Module, the Rivo™ Flex Mod Dis Measuring Module must be installed in module slot 1 or 2 in the Electronics Module.

Adjustment of the measuring signal input:

The μA signal input of the Rivo™ Flex Mod Dis Measuring Module is adjusted on the Measuring Module as follows:

The cell current of the 3-electrode measuring cell, the 3-electrode chlorine measuring cell or the membrane sensors (μA current signal) is directly proportional to the concentration of disinfectant in the sample water. Depending on the application, as an option, the μA measuring range at the sensor input can be adjusted to suit the specific conditions. This will normally not be necessary, due to the preset Auto Range function.

NOTICE

The setting for the μA measuring range depends on the cell, the disinfectant concentration and the type of disinfectant.

Guideline for setting:

The Rivo™ Flex Dis Measuring Module has three measuring ranges for the sensor current. These can either be selected manually or adjust themselves automatically to the measured signal via the Auto setting (Auto Range).

- 0 ... 10 μA
- 0 ... 100 μA
- 0 ... 1000 μA
- Auto

NOTICE

If the disinfectant concentration is high, select a higher μA measuring range. The parameter μA measuring range can be changed in the sensor settings menu of the corresponding Measuring Module.

This will normally not be necessary, due to the preset Auto Range function.

With the DEPOLOX®-R, a μA value of approx. 30 μA per 1 mg/l chlorine can be assumed as a reference value.

With the 3-electrode single-or chlorine measuring cell, a reference value of approx. 8 μA per 1 mg/l chlorine can be assumed.

With membrane sensors, a typical μA signal of approx. 10 μA per 1 mg/l chlorine can be assumed.

Setting the potential voltage U_{pot} - only with the 3-electrode measuring cell:

An adjustable potential voltage is output between working electrode and reference electrode. The potential voltage must be adjusted if disinfectants other than chlorine are measured:

- Chlorine: 250 mV (factory setting)
- Chlorine dioxide, ozone, potassium permanganate: 300 mV

The parameter “U_{pot}” can be set in the menu “Measuring range” of the corresponding Measuring Module.

Ambient conditions:

The following points must be observed when installing disinfection measurement:

- The sample water extraction point must be selected in such a way that proper mixing in of the disinfectant and a bubble-free sample water flow are guaranteed.
- The extraction line must be as short as possible. No water pipes made of copper may be fitted in the installation. They would falsify the measurement.

- If the flow module is not installed directly next to the Electronics Module, the measuring cell cable can be extended with a 3-core shielded cable with a maximum length of 30 m.
- As the multi-sensor for temperature measurement and flow monitoring is also integrated in the DEPOLOX®-R flow module, the latter must also be installed with a corresponding extension cable. Cables are available in graduated lengths of up to 30 m.
- The terminals must be used with connection direction right in the Electronics Module. For details of how to connect the sensor to the Measuring Module, see the Chapter “Wiring diagrams”.
- Initial calibration of the sensor can be carried out after approx. two to three hours running-in time.

NOTICE

The calibration must be checked after one day.

7.3.2 pH measurement

The pH value is a measurand in the field of water treatment. It is used as a measure of the acidic or alkaline effect of water. A pH single-rod measuring cell is used as a sensor.

For connection to the Electronics Module, the Rivo™ Flex Mod pH Measuring Module must be installed in module slot 1 or 2 in the Electronics Module.

Various controller functions are available, depending on the application selected.

The pH sensor can be installed in the flow modules DEPOLOX®-R 5, DEPOLOX® Pool-R, Varia Sens™-R or in a separate Flow-through Adapter.

The following points must be observed when installing pH measurement:

- The ambient conditions.
- The sample water extraction point must be selected in such a way that proper mixing in of the correcting agent and a bubble-free sample water flow are guaranteed.
- There is no prescribed flow rate here.
- The sensor must be dipped at least 2 cm into the sample water.

- Extension cables with connectors are available if the sensor or the flow module or Flow-through Adapter is not installed directly next to the Electronics Module.
- If extension cables (max. 30 m) are used, an impedance converter must also be fitted to the sensor to ensure a stable measuring signal.

NOTICE

Initial calibration of the pH sensor can be carried out after approx. two to three hours running-in time. The calibration must be checked after one day.

7.3.3 Redox measurement

The redox voltage is a measurand in the field of water treatment. The electrical potential present during a redox reaction is called the redox voltage and is used as a measure of the oxidation power of a system. The redox single-rod measuring cell is an extremely robust and low-maintenance single-rod electrode with a silver/silver chloride reference system.

For connection to the Electronics Module, the Rivo™ Flex Mod mV Measuring Module must be installed in module slot 1 or 2 in the Electronics Module.

Various controller functions are available, depending on the application selected.

The redox sensor can be installed in the flow modules DEPOLOX®-R 5, DEPOLOX® Pool-R, Varia Sens™-R or in a separate Flow-through Adapter.

The following points must be observed when installing redox measurement:

- The ambient conditions.
- The sample water extraction point must be selected in such a way that proper mixing in of the disinfectant and a bubble-free sample water flow are guaranteed.
- There is no prescribed flow rate here.
- The redox single-rod measuring cell must be dipped at least 2 cm into the sample water.
- Extension cables with connectors are available if the redox single-rod measuring cell is not installed directly next to the Electronics Module.
- If extension cables (max. 30 m) are used, an impedance converter must also be fitted to the redox single-rod measuring cell to ensure a stable measuring signal.

NOTICE

Initial calibration of the pH sensor can be carried out after approx. two to three hours running-in time.
The calibration must be checked after one day.

7.3.4 Fluoride measurement

Fluoride measurement using a fluoride-ion-sensitive sensor is used for continuous identification of fluorides in solutions. Measurement of the fluoride-ion concentration is selective. In order to ensure a correct measurement reading, the pH value of the medium must lie within a range of pH 5 to pH 8.

NOTICE

Rapid, repeated changes in temperature result in a constant change in the potential. This can cause functional failure of the sensor.

The fluoride electrode W2T840142 is filled with electrolyte. Electrolyte cannot be replenished.

For connection to the Electronics Module, the Rivo™ Flex Mod Fluoride Measuring Module must be installed in module slot 1 or 2 in the Electronics Module.

Various controller functions are available, depending on the application selected.

The fluoride sensor can be installed in the flow modules DEPOLOX®-R, DEPOLOX® Pool-R, Varia Sens™-R or in a separate Flow-through Adapter.

The following points must be observed when installing fluoride measurement:

- The ambient conditions.
- The sample water extraction point must be selected in such a way that proper mixing in of the disinfectant and a bubble-free sample water flow are guaranteed.
- There is no prescribed flow rate here.
- The fluoride sensor must be dipped at least 2 cm into the sample water.
- Extension cables with connectors are available if the sensor is not installed directly next to the Electronics Module.
- If extension cables (max. 30 m) are used, an impedance converter must also be fitted to the fluoride sensor to ensure a stable measuring signal.

NOTICE

The fluoride-sensitive membrane of the fluoride sensor is protected by a rubber cap. The rubber cap must be removed before the fluoride sensor is dipped into the sample water.

To prevent damage, avoid touching the membrane. Before use, the fluoride sensor should be placed in a 100 mg/l fluoride solution at pH 7 (e.g. calibration solution) for approximately 24 hours.

NOTICE

Initial calibration of the pH sensor can be carried out after approx. two to three hours running-in time. The calibration must be checked after one day.

7.3.5 Conductivity measurement

Conductivity is a sum parameter that measures the total mineralization of water. As this measurement is extremely temperature-dependent, the conductivity sensor has an integrated temperature sensor. The measurement is always given relative to a specific temperature value. The international reference temperature is 20°C or 25°C.

The conductivity sensor comprises a 4-electrode system with integrated temperature sensor. Conductivity sensors are made of graphite and are therefore extremely robust and abrasion-resistant. The cell constant is 0.48 cm⁻¹. The Measuring Module Rivo™ Flex Mod Con must be installed at the module slot of the Electronics Module. Various controller functions are available, depending on the application.

The sensor can be installed in the flow modules DEPOLOX®-R 5, DEPOLOX® Pool-R, Varia Sens™-R or in a separate Flow-through Adapter.

The following points must be observed when installing conductivity measurement:

- The ambient conditions.
- The sample water extraction point must be selected in such a way that proper mixing in of the disinfectant and a bubble-free sample water flow are guaranteed.
- There is no prescribed flow rate here.
- The conductivity sensor must be dipped at least 4 cm into the sample water.
- If the conductivity sensor is not installed directly next to the Electronics Module, the measuring cell cable can be extended with a connection socket and a 6-core shielded cable with a maximum
- length of 30 m.
- The terminals must be used with connection direction right. For details of how to connect the sensor to the Rivo™ Flex Mod Con Measuring Module, see the Chapter “Wiring diagrams”.

7.4 Controller modes (for W3T586961 only)

The Rivo™ Municipal/Industrial (W3T586961) offers various controller functions. Various controller modes such as ratio control, single feedback closed-loop control or combination control can be selected. Each controller is available for measurement channel 1 and 2. A total flow measurement for both measurement channels is available for flow-dependent controllers.

7.4.1 Ratio control without process measurement

In this controller mode, the Electronics Module works exclusively as a ratio control.

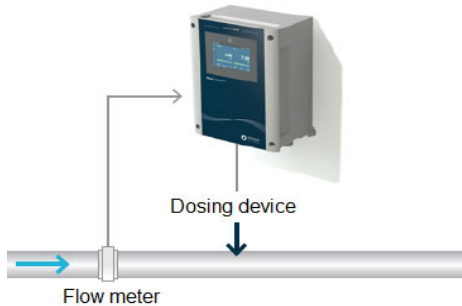

Fig. 6 Ratio control without process measurement

The dosing rate of the connected device is controlled automatically in dependency on a measuring signal (external flow control signal) and an adjustable dosing factor. In the case of actuators with feedback, it is possible to compensate for the non-linearity via a maximum of 11 calibration points.

Necessary module equipment:

- No sensor for recording measured values for, for example, chlorine, pH etc. is supported or evaluated.

Input signals:

- Flow measurement (0/4 ... 20mA), scalable measuring range with unit

The following dosing outputs are possible:

- Dosing pump
- Pulse pump
- Positioner with feedback 1kOhm / 5kOhm / 0 ... 1 V / mA signal
- Analog mA output

Operating principle of the ratio control:

Using the flow sensor with linear mA output signal, the flow rate is measured and the dosing rate adjusted proportional to the flow. Settings for the flow signal are made via the “Application Bar”.

NOTICE

If the measuring range end value of the flow meter is not equal to the actual, maximum flow, the flow signal must be adjusted. To do this, an upper calibration point input is entered as an mA value corresponding to the mA signal at maximum flow. A further value, to be displayed as max. display value for the flow rate, must be entered as upper calibration point output.

Example:

Measurement range flow meter = 5000 l/h

Actual maximum flow rate = 2500 l/h of the controlled system (corresponds to 50 % of the measuring range of the flow meter)

Input signal = 4 ... 20 mA (output, flow measurement)

Upper calibration point input signal = 12 mA (corresponds mathematically to 50% of the mA signal range)

Upper calibration point output signal = 2500 l/h

The ratio between control variable and dosing output is defined via the internal dosing factor.

If a positioner with feedback signal is used as a dosing output, it can be linearized with several data points. At least two points are necessary (0/100%). Up to 11 data points with firmly defined increments are possible.

In this operation mode, the controller output is calculated as follows:

Yout = Wq x DF	
Wq	Control variable 1 flow rate in %
DF	Set dosing factor in %

The graph below shows the output dosing quantity based on the flow rate Wq and the set dosing factor.

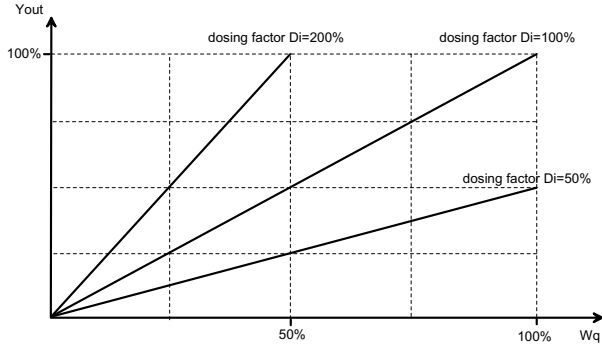

7.4.2 Ratio control with process measurement

In this operation mode, the quantity-proportional dosing of disinfectants is controlled. Ratio control with process measurement is only supported with the Rivo™ Municipal/Industrial (W3T586961).

A typical application is the simple, flow-controlled chlorination of drinking water. Controllers are available for each of the two measurement channels Mod1 and Mod2. The flow signal used is the same for both controllers.

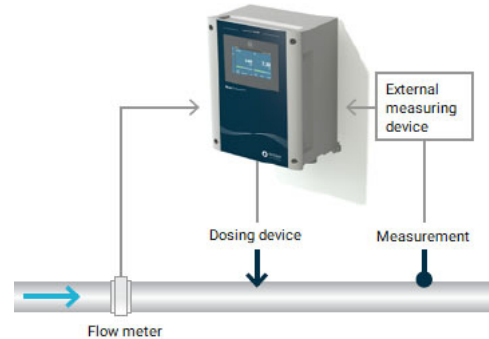

Fig. 7 Ratio control with process measurement

Necessary module equipment:

- Mod1 - for recording measured values
- Mod2 - for recording measured values

Input signals:

- Recording of measured values MOD 1 or MOD 2
- Flow measurement (0/4 ... 20mA), scalable
- Second control variable possible via sensor Measuring Module
- Internal or external dosing factor (0/4 ... 20mA)

The following controller outputs are possible:

- Dosing pump
- Pulse pump
- Positioner with feedback 1kOhm/5kOhm /0 ... 1 V/ mA-signal
- Analog mA output

Operating principle of the ratio control:

Using the flow sensor with linear mA/V output signal, the flow rate is measured and the dosing rate adjusted proportional to the flow.

Settings for the flow signal are made via the “Application Bar”.

NOTICE

If the measuring range end value of the flow meter is not equal to the actual, maximum flow, the flow signal must be adjusted. To do this, an upper calibration point input is entered as an mA value corresponding to the mA signal at maximum flow. A further value, to be displayed as max. display value for the flow rate, must be entered as upper calibration point output.

Example:

Measurement range flow meter = 5000 l/h

Actual maximum flow rate = 2500 l/h of the controlled system (corresponds to 50 % of the measuring range of the flow meter)

Input signal = 4 ... 20 mA (output, flow measurement)

Upper calibration point input signal = 12 mA (corresponds mathematically to 50% of the mA signal range)

Upper calibration point output signal = 2500 l/h

The ratio between control variable and dosing output is defined via the internal dosing factor or can be specified via an external mA/V input signal.

It is possible to switch between internal and external dosing factor via the digital input. Alternatively, an external dosing factor can be specified via the optional interfaces.

7.4.3 Single feedback closed-loop control with process measurement

In this operation mode, the desired measurand is controlled in accordance with a prescribed setpoint.

The following image shows a typical application for a chlorine single feedback closed-loop control with a constant flow rate.

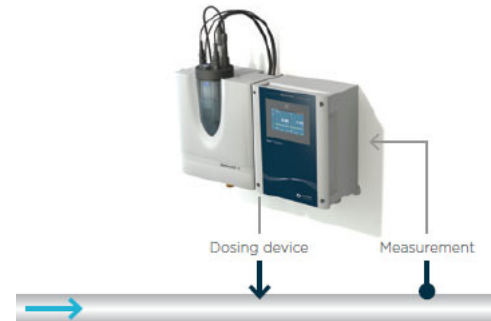

Fig. 8 Single feedback closed-loop control with process measurement

Necessary module equipment:

- Rivo™ Flex module for recording measured values at module slot 1 and 2

Input signals:

- Measured value recording module
- Internal or external setpoint

The following controller outputs are possible:

- Dosing pump
- Pulse pump
- Positioners with/without feedback (1kOhm/5kOhm/0 ... 1 V/mA-signal)
- Analog

Operating principle of the single feedback closed-loop control:

A PI controller is used to control the measurand from the sensor Measuring Module to the desired setpoint constantly and without deviation. It continuously determines the required dosing output.

The setpoint can be set within the measuring range ("Setpoint source" = internal).

Xp and Tn serve as control parameters to be set. They can also be determined automatically via the integrated Auto tune function during chlorine regulation.

An external setpoint from 0 – 100% can be preset via the mA/V input signal. It is possible to switch between internal and external setpoint via the digital input. Alternatively, the setpoint can be specified via the optional interfaces.

The control direction of the controller can be selected with the parameter "Control direction" = direct or inverse (e.g. direct = chlorination, inverse = dechlorination).

In this operation mode, the controller output is calculated as follows:

$Y_{out} = Y_{pi} = e_k \times K_p \times (1 + t/t_n)$	
t	Controller sampling time
t _n	Integral action time
K _p	Proportional factor 100 / X _p
e _k	Deviation setpoint-actual value
Y _{pi}	PI controller output value
Y _{out}	Determined controller output value in %

7.4.4 Combination control with process measurement

This operation mode combines ratio control with additional single feedback closed-loop control for the correction of control deviations. With the advantages of both operation modes, combination control ensures that the measured values are regulated to the setpoints as quickly as possible if there are changes in the flow.

The image below shows a typical chlorine combination control as realized in the treatment of drinking water.

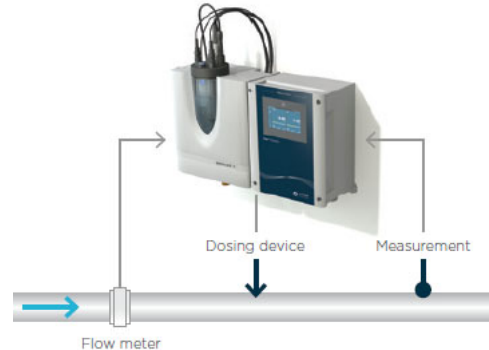

Fig. 9 Combination control with process measurement

Necessary module equipment:

- Rivo™ Flex module for recording measured values at module slot 1 and 2

Input signals:

- Flow measurement (0/4 – 20mA), scalable
- Measured value recording module
- Internal or external setpoint

Output parameters:

- Dosing pump
- Pulse pump
- Positioners with feedback (1kOhm/5kOhm)
- Analog

Operating principle of the combination control:

With combination control, a dosing rate is output proportional to the flow. This dosing rate does not have a fixed dosing factor proportional to the flow, as with ratio control, but instead, varies as needed.

Control deviations are detected via recording of the control value with Sensor Measuring Module and the specification of a setpoint. They are then compensated for by the integrated single feedback closed-loop controller.

The internal setpoint can be set within the measuring range. Prerequisite is "Setpoint source" = internal. An external setpoint from 0 – 100% can also be preset via the mA input signal. Prerequisite is "Setpoint source" = external. It is possible to switch between internal and external setpoint via digital input.

Prerequisite is "Setpoint source" = "external with DI3" or "internal with DI3". Alternatively, the setpoint can be specified via the optional interfaces.

Control parameters X_p and T_n of this superimposed single feedback closed-loop controller are determined with the integrated logic, while the process times T_{const} and T_{var} , to be entered at 100% flow, are determined automatically. As process time T_{var} changes dependent on the flow, T_{var} and X_p as well as T_n are continually updated via the integrated fuzzy logic.

The Electronics Module operates internally with a dosing factor table for 0 ... 105% flow. During operation, the device automatically determines the required dosing factors based on the corresponding flow, in 5% increments. The corrections made by the single feedback closed-loop controller are entered in the dosing factor table. In this way, non-linearities of the control loop are learned. In the event of changes in the flow, this means rapid regulation of the setpoint.

The dosing factor table can be checked in the menu. It is possible to delete the entire dosing factor table and preset a specific dosing factor.

(Factory setting: 50%), to ensure that dosing rates are not too high, for example during commissioning. This is done by entering the desired dosing factor in the menu "System" - "Reset" - "Flow rate delete".

It is possible to switch to controller operation mode ratio control or single feedback closed-loop control via digital input.

The control direction of the controller can be selected with the parameter "Control direction" = direct or inverse (e.g. direct = chlorination, inverse = dechlorination).

Behavior during operation - operation after a change in flow rate:

The single feedback closed-loop controller remains switched off (Ypi stop function) for the duration of the disturbance variable (change in flow rate, positioner runtime, dead time due to line length). This holds the control stable, i.e. the controller operates

with the dosing factor valid for the new flow from the dosing factor table. The switch-off time for the single feedback closed-loop control is determined via the fuzzy module and is therefore variable (display "PI" in seconds).

The effect of the disturbance variable, or the size of the change in the flow rate that triggers the YPI stop function, can be defined via the parameter "PI switch-off".

A major change in setpoint value deletes all ??? counters to re-initialize the dosing factor characteristic curve when the setpoint is reached.

For the moment, however, the learned flow values remain unchanged. A dosing factor is automatically preset for non-regulated flow values. The single feedback closed-loop controller is always active.

At constant flow, any control deviations that occur are quickly compensated for by the PI single feedback closed-loop controller.

In the case of a positive jump in the flow rate, the setpoint is briefly undershot due to the running time of the positioner and the dosing delay. For this reason, the PI controller is frozen for a short time (display "PI" in seconds).

In the case of a negative jump in the flow rate, the setpoint is briefly exceeded due to the running time of the positioner and the dosing delay. For this reason, the PI controller is frozen for a short time (display "PI" in seconds).

The PI controller is not deactivated where the dosing rate can keep pace with a continually rising or falling flow rate. This applies in the case of fast positioner running times and control loops without dosing delay.

Special functions:

- The control direction of the controller is reversible.
- Automatic determination of the control parameters using integrated logic.
- System determines the internal control parameters based on the entered process times Tconst and Tvar.
- Setpoint can be switched between internal and external.
- Ypi stop function with change in control variable.
- Directly or indirectly proportional control variable Wq can be selected, and factor adjustment is possible.
- Bumpless transfer from combination control to ratio control or single feedback closed-loop control is possible via digital input 1, 2 or 3.

Yout =	
Wq x (DFWq + ek x Kp x (1 + t/tn))	
Ratio	single feedback closed-loop
t	Internal controller sampling time
tn	Integral action time
Kp	Proportional factor 100 / Xp
ek	Deviation setpoint-actual value
DFWq	Learned dosing factor for the current flow rate
Wq	Flow signal in %
Yout	Determined controller output value in %

Determining process times of the combination control:

For controller adjustment with the combination control, the process times Tconst and Tvar must be entered in the parameter menu path. These times are control loop dead times that on one hand are independent of the control variable and on the other are proportional to the control variable.

The constant dead time < Tconst > (independent of control variable) consists of the dead time of control variable measurement (measuring dead time) and any dosing delays.

The variable dead time < Tvar > depends on the current control variable and is given in the menu with a control variable of 100%.

The following sample calculations apply to the use of the Electronics Module for flow-controlled chlorine dosing with excess chlorine correction (drinking water control loop).

Determining the control-variable-independent dead time T_{const} :

The control-variable-independent dead time T_{const} consists of the measuring dead time and the dosing dead time.

Calculation 1 of the measuring dead time:

The sample water is extracted directly after the mixing loop and routed to the measuring cell.

The sample water dead time depends on the nominal diameter of the sample water line and the rate of flow to the measuring cell. For the DEPOLOX®-R, a flow value of 36 l/h is assumed.

For the DEPOLOX®-R:

$$t_{sw} \text{ (DEPOLOX®-R)} = (d_{sw} \times d_{sw} \times l_{sw}) : 7.65$$

(result in min)

The following applies in general:

$$t_{sw} = (4.71 \times d_{sw} \times d_{sw} \times l_{sw}) : Q_{sw} \text{ (result in min)}$$

d_{sw}	Internal diameter of the sample water line in cm
l_{sw}	Length of the sample water line in meters
Q_{sw}	Rate of flow to the measuring cell in l/h

Example:

The sample water line is a DN6 line with a length of 10 meters and is connected to the 3-electrode measuring cell (DEPOLOX®-R).

$$t_{sw} = (0.6 \times 0.6 \times 10) : 7.65 \text{ min} = 0.47 \text{ min, i.e. approx. 28 sec.}$$

Calculation 2 of the measuring dead time:

The sample water extraction is equipped with an additional sample water pump (bypass line).

The sample water dead time depends on the flow capacity of the sample water pump, on the nominal diameter of the bypass line and the length up to the sample water branch-off to the measuring cell.

$T_{by} = (4.71 \times d_{by} \times d_{by} \times l_{by}) : Q_{by}$	
d_{by}	dby Internal diameter of the bypass line in cm
l_{by}	Length of the bypass line from the sample water extraction to the sample water branch-off to the cell in meters
Q_{by}	Flow capacity of the bypass pump in l/h (result in min)

Check whether the length of the sample water line to the measuring cell can be neglected. If necessary, calculate the sum of calculation 1 and 2.

Calculation 3 of the measuring dead time:

The sample water extraction is designed as in calculation 1 and/or 2. In addition, for a longer exposure time, the water is routed through a delay tank.

The exposure time in the delay tank must be added to the calculated time.

Determining the dosing dead time (dosing delay):

Dosing dead times are caused by long dosing lines and positioner running times.

Determining the dosing dead time - calculation 1:

Determination of the dead time caused by dosing line lengths.

The dosing dead time can be determined as follows:

$t_{dos} = (4.71 \times d_{dos} \times l_{dos} \times Q_{dos}) : Q_{dos}$ (result in min)T	
d_{dos}	Internal diameter of the dosing line in cm
l_{dos}	Length of the dosing line in meters
Q_{dos}	Flow capacity of the dosing line in l/h

Determining the dosing dead time - calculation 2:

If rapid changes in control variable with which the actuators cannot keep pace are expected in the system (e.g. positioner running times, cycle time of dosing pumps), the dosing delay time must be assumed to be half the positioner running time t_y and cycle time t_p .

With a positioner running time of 80 seconds, a value of approx. 40 s must be calculated as constant dosing delay. The sum of the measuring dead time and dosing delay is entered in minutes in the menu < Tconst >.

Determining the control-variable-dependent dead time T_{var} :

The control-variable-dependent dead time T_{var} is dependent on the nominal flow rate, the internal diameter of the pipe and the distance between chlorine addition point and sample water extraction.

$t_{var} = (d_{pipe} \times d_{pipe} \times l_{pipe}) : (212.3 \times Q_{nom}$ (result in min)	
d_{pipe}	Internal diameter of the pipeline in cm
l_{pipe}	Distance between chlorine addition point and sample water extraction in meters
Q_{nom}	Nominal flow rate in m ³ /h (corresponds to the flow rate specified as 100% flow signal for the controller)

If there are special reaction tanks in the system, these tanks must be considered separately.

7.5 Control parameters

Control parameters are input variables that determine the control functions of a controller. Different parameters apply to each type of controller.

Flow rate direction

This parameter determines the direction of the flow rate signal directly proportional to the actuator output:

direct = Flow rate input signal directly proportional to the positioner output (factory setting)

inverse = 1 flow rate input signal

Example:

0 – 100 % flow rate = 0 – 20 mA (direct)

0 – 100 % flow rate = 20 – 0 mA (inverse)

Max. pulses/min

Meaning: Maximum number of pulses

Explanation: The pulses max./min parameter only applies to pulse pumps.

This parameter is used to set the maximum number of pulses per minute in accordance with the employed pump.

Setting range: The parameter max. pulses/min. can be set to 100, 120, 140, 160 or 180pulses.

Max.lin.Correction

This parameter monitors changes to already learned dosing factors.

If new dosing factor changes are learned, which are larger than the max. linearity correction, this dosing factor is used for all values in the dosing curve => initialization of the curve.

Special case:

Max.lin.Corr. = 0:

The curve function is turned off, only one dosing factor is valid for all flow rates and the higher-level single feedback closed loop control remains active.

Example:

Max.lin.Corr. = 50 % (based on dosing factor):

Previous dosing factor: 30 %

Newly learned dosing factor: 48 %

max. permissible correction range: $30 \pm (50 \% \text{ von } 30 \%) = 30 \% \pm 15 \%$

Change in this case: $48 \% - 30 \% = +18 \%$

=> The new dosing factor is assumed for the entire curve, because the new dosing factor (+48%) is greater than the max.lin.Correction (+18%).

Control factor

Setting the ratio of control range and measuring range, in order to adjust the control amplification X_p to the process.

Control factor = (End of measuring range - start of measuring range) : Control range

Example:

Start of measuring range: pH 4

End of measuring range: pH 9

Max. process control range: $\pm 1 \text{ pH}$ ($\Rightarrow 2 \text{ pH}$ increments) \Rightarrow Control factor = $(9 - 4) : 2 = 2.5$

PI shutdown

Defines a range for flow rate changes triggered by the YPI stop function when the limit is exceeded. Factory setting = 5%, i.e. if the change in flow rate is greater than 5% the PI controller is frozen for a specific length of time. Adjustment range 5 to 100 %.

Control direction

Meaning: Direction of the control

Display: Direct/inverse (e.g. for pH)

Explanation: Defines which medium is used to perform the correction.

Example:

pH: Control direction "inverse": Lowering pH value by adding acid

pH: Control direction "direct": Adding alkaline to raise the pH value

Setpoint

Specified value at which the control variable can be maintained by the controller. The setting range corresponds to the respective measuring range.

Bumpless-Transfer

This parameter enables the current dosing capacity to be transferred to the following operating mode or controller mode when the operating mode and controller mode are changed. This keeps the dosing and therefore the current measurement stable. The function can be activated or deactivated once or permanently.

Dosing delay time

The dosing delay time delays the start of dosing after switching on the appliance and after changing the operating mode.

Safety MAN. Mode

If this parameter is set to ON, dosing also stops in manual mode if the sample water flow is too low or if an external stop occurs.

Source dosing factor

This parameter defines the source of the dosing factor active for the control. This can either be the internally set dosing factor of the menu setting or the dosing factor as an external mA signal input or interface interface.

Setpoint source

This parameter defines the source of the setpoint active for the control. This can either be the internally set setpoint value of the menu setting or the setpoint value as external mA signal input 2 or interface interface.

Switch-off threshold

Defines a switching threshold in combined control mode above which changes in the flow rate freeze the PI control for a certain period of time (depending on the process times and the flow rate value).

Tn

Meaning: Integral action time (I-element)

Display: Minutes (min)

Explanation: On the basis of the integral action time Tn, the dosing capacity changes constantly until the setpoint is reached. The higher the value of Tn, the longer it takes until the controller increases the dosing rate.

Tn higher: Control response becomes slower

Tn lower: Control response is faster

Setting range: The parameter Tn can be set from 0 – 100 min (Tn = 0 means that the "I-element" is deactivated, i.e. a pure P-control response applies). It may not be possible to reach the setpoint value.

Tp

Meaning: Cycle period

Display: Seconds (s)

Explanation: The parameter Tp only applies to dosing pumps.

The cycle period Tp defines a switching period, which must be coordinated with the respective pump type.

Setting range: The parameter Tp can be set from 10 to 180 s.

Example:

Fast dosing pumps correspond to a low Tp;
slow dosing pumps correspond to a high Tp.

The control parameter Tp must always be adjusted to suit the pump employed:

Dosing pump strokes/ min	Tp value
up to 20	120
20 to 40	100
40 to 80	60
80 to 125	30
125 to 200	15

Ts

Meaning: Loop rise time

Display: Minutes (min)

Explanation: Time required to reach the measuring range end value with 100% dosing chemical supply.

Setting range: The parameter Ts can be set from 1 s to 8 h.

NOTICE

If the values Tu and Ts are manually modified, the control parameters Xp and Tn are re-calculated.

Tu

Meaning: Loop dead time

Display: Seconds (s)

Explanation: Time required between dosing start and clear recognition of the rise in the control variable

Setting range: The parameter Tu can be set from 1 s to 59 min 59s.

NOTICE

If the values Tu and Ts are manually modified, the control parameters Xp and Tn are re-calculated.

Ty

Meaning: Running time of the positioner

Display: Seconds (s)

Explanation: The parameter Ty only applies to positioners.

Ty is the time which the positioner requires to adjust from 0 % to 100 %.

Setting range: The parameter Ty can be set from 10 to 180 s.

Xp

Meaning: Proportional factor

Display: Percentage (%) with factor

Explanation: The control amplification is determined with the proportional factor.

The lower the proportional factor Xp is selected in % , the greater the deviation from the setpoint is amplified, and the more quickly the controller attempts to control the deviation from the setpoint.

The control amplification factor is calculated using the following equation:

$$\text{Factor} = (1/Xp) \times 100 \%$$

Setting range: The parameter XP can be set from 1 % (factor 100) – 1000 % (factor 0.1).

Xsh

Meaning: Neutral zone

Display: Percentage (%)

Explanation:

The parameter Xsh only applies to 3-point controllers.

No control output occurs in the neutral zone.

Setting range: The parameter Xsh can be set from 1 to 5 % (depending on the measuring range).

The neutral zone is the defined range of setpoint + X_{sh} to setpoint X_{sh} .

Ym calibration

This parameter is only possible for dosing output positioner with feedback.

Adjust the positioner feedback signal to 0 % and 100 % dosing capacity. When automatic Ym calibration is started, the positioner moves to positions 0 % and 100 % and calibrates both positions with the Electronics Module.

With manual calibration of the up-to-11 positions, all positions must be shifted to manually and the dosing capacities are entered manually.

Feedback Threshold

This parameter defines the accuracy of the positioning of the servomotor with feedback.

Switching to ratio control

If this function is activated, the controller mode switches from combined control to ratio control when the flow rate falls below the defined threshold value. This can be helpful if low flow rates cause long process times and unstable control results. The last dosing factor output is used as the dosing factor in order to keep the measurement results stable or constant.

Ymax

Meaning: Dosing rate limitation (single feedback control-loop control only)

Display: Percentage (%)

Explanation: The parameter Ymax only applies to:

- Positioner with feedback
- Dosing pumps
- Solenoid pump
- Controller with mA output

Ymax defines the maximum control output to the actuator
The control parameter corresponds to electronic dosing limitation of the actuator.

Setting range:

The parameter Ymax can be set from 0 to 100 %.

Ymin

Meaning: Dosing rate basic load (single feedback control-loop control only)

Display: Percentage (%)

Explanation: The parameter Yminonly applies to:

- Positioner with feedback
- Dosing pumps 2p
- Solenoid pumps 2p
- Controllers with mA output 2p

A basic dosing rate is output to the actuators with Ymin.

Setting range: The parameter Ymincan be set from 0 to 100 %.

NOTICE

Ymin and Ymax is only available for the single feedback closed-loop control.

The control range is limited by the parameters Ymax and Ymin.

Do not select a Ymax value lower than Ymin.

At Ymin> 0 overdosing can occur.

7.6 Display of dosing quantity

The Electronics Module allows a freely configurable dosing quantity display (Yout). In the menu, see device, the dosing quantity can be left as a value 0 to 100% or freely configured as a dosing quantity, e.g. 0 to 10.0 l/h, 0 to 4.0 g/h, etc. Format and unit are freely selectable - see menu on the device.

7.7 Digital inputs DI 1 and DI 2

CAUTION

Danger caused by external voltages at the digital inputs

Possible consequence: Serious material damage.

- Do not apply external voltages at the digital inputs.

There are two integrated digital inputs on the Rivo™ Backboard 4. They are provided for connection of voltage-free contacts (< 100 Ohm) and are supplied internally with 24 V.

The functions of the digital inputs can be configured for the specific customer application in the menu on the device.

It is possible to influence the controller or trigger alarms. Various functions can be assigned to the digital inputs. With the help of a voltage-free enabling contact, e.g. external stop, it is possible to realize the various functions:

- Alarm (freely configurable)
- Ext. stop: Dosing is switched off.
The positioner moves to 0 %.

- Empty signal contact of the chemical tank(s).
The dosing pump is switched off.
The positioner moves to 0 %.
- Switchover between internal and external dosing factor.
- Switchover between controller modes ratio, single feedback closed-loop, combination control.

NOTICE

When the contact closes, restart of the controller may be delayed due to the dosing delay time. In as-delivered status, the digital inputs are disabled. To activate the function, configure the digital input in the menu. The digital inputs can also be assigned as alarms.

The digital inputs can be configured as direct or inverse so that they switch to active state as NC or NO contacts.

7.8 Sample water monitoring**WARNING****Danger caused by uncontrolled dosing and incorrect circulation output**

If there is a shortage of sample water or the flow rate is too low, if the circulation is switched off or the circulation output is too low, there is a risk of uncontrolled dosing of chemicals.

Possible consequence: fatal or serious injury.

- Never disable the sample water monitoring - even temporarily, e.g. by bridging the signal input.
- Chemical dosing must switch off if the circulation is switched off or if the circulation output or flow rate is too low. To ensure this, circulation output or flow rate monitoring must be installed in the system and connected to the Electronics Module.

7.9 mA inputs, Rivo™ Backboard 4

There are two integrated mA inputs on the Rivo™ Backboard 4. mA input 1 is used to record the flow signal as a 0 to 20 mA or 4 to 20 mA signal. The input signal can be freely configured in the menu (see menu Input/Output). Format, range and unit are freely selectable. mA input 2 is used to record an external dosing factor specification via a 0 to 20 mA or 4 to 20 mA signal. The mA signal corresponds to a dosing factor of 0 to a maximum of 400% or an external setpoint within the selected measuring range.

7.10 Connections to visualization systems

The following options are available for connecting the Electronics Module to a higher-level visualization or control system:

- Ethernet interface with Modbus TCP and HTTP protocol (standard)
- Optional 2-way mA signal output module “Rivo™ Flex Mod 2AO-mA”
- Optional “Rivo™ Com-Board 485” expansion board with RS485 interface (Wallace & Tiernan protocol). See Chapter 7.18 Interfaces.

NOTICE

For detailed information on the interfaces, see the separate installation manual “Rivo™ Communication Interfaces”. You can request this installation manual from us or download it from our homepage.

7.11 Controller outputs

The Electronics Module supports the activation of various dosing systems via relay or mA-signal outputs. Module slots are provided for optional expansion with further relays.

The following dosing outputs can be activated:

Controller for	Type	Parameter designation	Action
Positioner with feedback signal	3-point	Positioner with Ym	Dosing ↑ or ↓
Motor dosing pump (pulse-duration controller)	2-point	Dosing pump 2p	
Solenoid pump (pulse-frequency controller)	2-point	Solenoid pump 2p	
Dosing pump with mA input	2-point	Analog output 2p	

7.11.1 Positioner (with feedback)

With the selection of the positioner, for example, it is possible to use chlorine gas dosing in combination with a positioner as an actuator of a chlorine gas dosing system. If actuator feedback is present, it must be calibrated during startup. Potentiometers 1 kOhm/5 kOhm or 0 to 1 V or 0/4 up to 20 mA signals can be connected as actuator feedback (see Chapter 7.13 Positioner feedback). Linearization of the actuator via several calibration points is possible here.

7.11.2 2-point pulse-duration controller for dosing pumps

The dosing pump is switched on for the calculated time within an adjustable cycle period TP (relay contact). The cycle period is mainly determined by the reaction time of the connected system and entered as the cycle period TP.

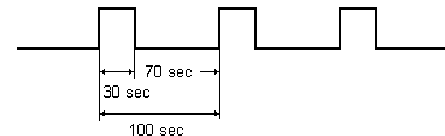

Example:

Cycle period TP = 100 s

Duty cycle 30 s

Output value Yout = 30%

Off time 70 s

7.11.3 2-point pulse-frequency controller for solenoid pumps

Solenoid pumps are controlled with 0 to a maximum of 180 pulses per minute, depending on the specification of the connected pump. The Electronics Module supports pumps with 100, 120, 140, 160 and 180 pulses per minute.

The minimum duty cycle is 0.15 s. The pause time is calculated depending on the dosing rate.

Example of a solenoid pump at 120 pulses/min:

Yout in %	Pulses/min
100...	120...
84...	96...
72...	85...
56	75
50...	60...
33...	40...
25...	30...
10...	12...
5...	6...
10	10

7.11.4 Analog 2-point output

As an option, the Electronics Module can be retrofitted with a 2-way mA output module (Rivo™ Flex Mod 2AO mA). These mA outputs can be configured as registration or control outputs.

In the selection “Analog output 2p,” the mA output is firmly assigned as a control output.

With a control output of 0%, the output current is 0 or 4 mA, while with a greater Yout, the output current reaches up to 20 mA. Dosing pumps with mA control input, control valves with mA signal input, for example, can be used as actuators.

7.12 mA outputs

As an option, the Electronics Module can be equipped with a Rivo™ Flex Mod 2AO-mA 2-channel output module. Both mA outputs are electrically isolated and can be freely assigned. The output signals can be configured as 0 to 20 mA and 4 to 20 mA.

If an mA value of 3.4 mA is not reached in the setting 4 to 20 mA, this is detected as a line break and an error is generated.

7.13 Positioner feedback

When a positioner with feedback (positioner with Ym) is used as dosing output, the actual position of the positioner/dosing rate is transferred to the control device via selectable input signals in order to achieve the best possible control result. Various feedback options are available:

- Potentiometer 1 kOhm
- Potentiometer 5 kOhm
- 0...10V
- 0/4...20mA

The feedback signal used can be set in the menu. For an optimum control result, the position feedback must be aligned (calibrated) with the controller. The positioner feedback end points 0% and 100% must always be calibrated. This can be done by running the automatic positioner calibration function. The controller automatically approaches the 100% and the 0% position and saves the corresponding values measured for the feedback signal internally. The positioner runtime T_y is automatically determined during the calibration process. During calibration, the positioner must not be unlocked for manual operation.

If the dosing rates between 0% and 100% are not linear to the position feedback, these non-linearities can be compensated for or linearized via correction values between 0 and 100%. Up to 11 further positions can be corrected to compensate for non-linearities in the dosing.

Procedure:

In order to calibrate further data points, select desired calibration points between 0 and 100% and set the required dosing output to correct the linearity.

7.14 Digital outputs

As an option, the Electronics Module can be equipped with a Rivo™ Flex Mod 2Rel-2DO. It makes two further relay outputs and two digital outputs available, which can be configured as alarm outputs. The digital outputs are optocoupler switching outputs for the power-free activation of dosing devices. The maximum control voltage (external) of 24 V DC and a maximum switching current of 20 mA must be observed here (these digital outputs are not supported in the Rivo™ I).

7.15 Relay outputs

The Electronics Module has two on-board relays and can be expanded with relay modules. Further relays can be added as modules. To do this, the Rivo™ Flex Mod 2Rel-2DO must be installed. The modules are configured via the menu setting. These switches are assigned various switching tasks depending on the respective application. See the Chapter “Device configuration”.

The connection and switching of non-approved devices/ loads destroys the relay contacts. The device then functions in an uncontrolled manner! In order to switch inductive loads or capacitive loads that exceed the technical properties of the relay contact, an additional switching element such as a contactor or load relay with suitable specifications must be installed. To suppress radio interference, the relay contacts are protected internally by suppressor diodes.

All on-board relays are protected by fuses. They act as overcurrent limiters protecting the terminal and relay connections. The fuses of the backboard are replaceable (Type TR5, T3,15A). To fuses of the Rivo™ Flex Mod 2Rel-2DO are not replaceable.

NOTICE

If the internal power supply L1 and N/L2 is used for dosing pumps or other devices, the current consumption must not exceed the value of the selected back-up fuse.

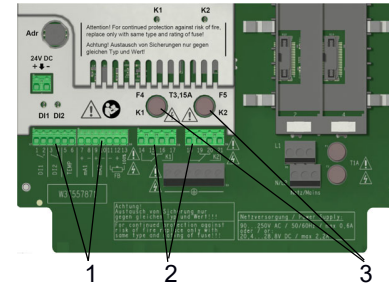

Fig. 10 Detail of PCB - relay outputs

- 1 Terminal strips for control inputs
- 2 Terminal strips for relays
- 3 Fuses of the Rivo™ Backboard 4 relay

NOTICE

If the internal power supply L1 and N/L2 is used for dosing pumps or other devices, the current consumption must not exceed the value of the selected back-up fuse.

7.16 Messages and alarms

Alarms, warnings, messages are displayed by means of a colored message symbol (🔔 alarm bell) and a RGB LED above the display.

Red symbol:	error active
Yellow symbol:	warning active
Neutral symbol:	general notes

Tap the alarm bell to open the message window. All active messages are displayed with text. Acknowledgeable messages are confirmed or acknowledged with the ACK button.

7.16.1 Configuration

The Electronics Module supports the creation of freely configurable alarms. The alarms are output optionally via relay contacts and a color message display. At the same time, a message is displayed in the message system. The number of available relays depends on the configuration. The alarm relays can be used, for example, for safety deactivation of dosing when specific values are exceeded or not reached. The assignment of a relay as a switching function is optional.

Each alarm can be configured as described below. Multiple assignment is possible:

Message	freely configurable text
Description	freely configurable text
delay time	hh:mm:22 00:00:00 to 10:49:59
Notification level	Error/warning
Acknowledge	Without/simple ACK/ACK with reset
Assignment	Single/multiple assignment
Relay assignment	Assignment to relay

7.16.2 Without Acknowledge

- The alarm symbol and the message symbol light up in the event of an alarm and go out automatically when the condition is eliminated.
- Unlatched alarms are displayed in yellow as messages.
- The relay is active when the alarm symbol is displayed and the alarm is active.

7.16.3 ACK with reset

- In the event of an alarm, the alarm symbol and the message symbol flash and the relay is active until acknowledged.
- The alarm symbol and the message go out even if the conditions still apply when the alarm is acknowledged.
- Latched alarms are displayed in red as messages.
- The relay becomes inactive after acknowledgment if the condition is still pending.

7.16.4 Simple ACK

- The relay becomes active as soon as the alarm is active.
- In the event of an alarm, the alarm symbol and the message symbol flash until the alarm is acknowledged.
- If the condition is no longer present when the alarm is acknowledged, the alarm symbol goes out and the message disappears.
- If the condition is still present when the alarm is acknowledged, the alarm symbol and the message are reset from flashing to a permanent state. The alarm symbol and the message light up until the condition is eliminated (auto-reset).
- Latched alarms are displayed in red as messages.
- The relay is only deactivated when the condition has been eliminated and acknowledged.

7.16.5 Safety functions

Various safety functions are integrated to ensure system safety and minimize the risk of accidents:

- alarms freely configurable
- external STOP for dosing (depending on the configuration of the digital inputs)
- password protection
- Safe manual mode stops dosing if the sample water flow rate is too low or in the event of an external stop or external stop in manual mode.
- Secure calibration switches off the dosing if the calibration is not completed.

7.17 Status LED states

The Rivo™ Flex modules use LEDs to provide information about the operating status of the module.

LED	Status	Modus	Description
white	illuminated	BOOT	Only displayed briefly during booting. Module restarts.
red	illuminated	STOP	Module is in stop mode. No outputs active, or output based on Stop-Behavior.
green	illuminated	RUN	The module is in run mode. All outputs are active and are activated. This is the normal state during operation.

LED	Status	Modus	Description
red	flashing	STOP, TIMEOUT	Module has switched to stop mode due to a communication interruption after a timeout has expired. If this state occurs, communication with the control unit has been unexpectedly interrupted.
blue	flashing	UPDATE	Module is in update mode. Firmware update is being carried out.

7.18 Interfaces

WARNING

Danger due to inadequately qualified personnel

Possible consequence: fatal or serious injury and significant material damage.

- To ensure safe operation and prevent serious injury, the device must be installed by trained and authorized specialist personnel.

NOTICE

- See Chapter Design of the HMI and the Backboard.
- For more detailed information, please refer to the installation manual "Rivo™ communication interfaces." You can request this installation manual from us or download it from our homepage.
- The firmware update can be downloaded free of charge from our homepage.

7.19 USB interface

The Electronics Module is equipped with a USB interface. It can be used for the following:

- Transfer of firmware updates. Download via our homepage.
- Transfer of configuration data for reproduction and back-up of a configuration.
- Download of the internally saved archiving data.

7.19.1 Firmware update via USB interface

The firmware can be updated using a USB stick. The firmware file can be downloaded free of charge from our homepage.

You can read off the currently installed firmware version of the CPU in the system menu  under system information - Software information.

NOTICE

For information on installing a firmware update, see Chapter Firmware update via USB interface.

7.19.2 RS485 interface (optional)

As an option, the Electronics Module can be equipped with a Rivo™ Com-Board 485 expansion board. This expansion board has an integrated RS485 interface. The RS485 interface is used for data transfer to higher-level control systems or other systems that support the Wallace & Tiernan RS485 protocol. The RS485 interface is electrically isolated. It has four integrated terminals and a terminating resistor R_t for incorporation into a Wallace & Tiernan bus system.

NOTICE

For information on installing the Rivo™ Com-Board 485 expansion board, see Chapter RS485 interface (optional).

7.19.3 Ethernet interface (HMI)

HINWEIS

This instruction manual does not cover installation and commissioning in combination with routers or wireless routers. Responsibility for this lies with the operator.

- For security reasons, access to the device should only be granted to authorized personnel.
- Permanent, unsafe connections via the Internet or WLAN are not permitted. Safe connections can, for example, be set up via a VPN-secured communication channel or an encoded WLAN connection.
- The Electronics Module only supports the unencrypted communication protocol “http” and is designed for operation within an Intranet (closed network) (Chapter Safety - IT security).

The Electronics Module has an integrated Ethernet interface.

The installed LAN interface allows data visualization via an Internet-capable device and HTTP protocol or standard browser. The LAN interface also supports data communication with higher level control systems via Modbus TCP protocol.

Visualization and operation are effected via the web pages integrated in the Electronics Module. Wireless access via mobile devices such as tablet computers or smartphones is possible by installing a wireless router on-site and connecting it to the Electronics Module.

The Ethernet interface supports a transmission rate of 100 Mbit/s.

The Ethernet interface is electrically isolated.

Connection is via a standard Ethernet connection cable. To allow the use of pre-terminated Ethernet cables with connectors, one special M25 cable gland with slit rubber seals and larger grommets is installed. The Ethernet connectors can be inserted through these fittings.

The Ethernet connection is designed in accordance with IEEE 802.3. There is a RJ45 socket installed at the HMI. Connection to a network is possible using a patch cable (1:1) or a crossover cable (crossover network cable). The LEDs are fitted in the RJ45 socket. They display the interface statuses.

LED	Status	Meaning
green	illuminated	Ethernet connection established
green	flashing	Data being transferred
yellow	off	10 Base-T
yellow	illuminated	100 Base-T

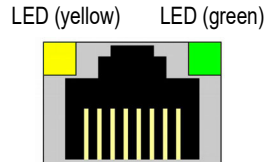

Fig. 11 Ethernet connection

The connection runs in Auto negotiation mode. The data transfer rate and full or half duplex are defined automatically with the connected switch/HUB.

8 INSTALLATION

⚠ DANGER**Danger of fatal injury caused by electric shock**

External voltages may still be connected even if the operating voltage is switched off.

Possible consequence: fatal or serious injury.

- All electrical installation work must be performed by a qualified electrician.
- Work on the device must be carried out when it is in de-energized state.
- Do not carry out work on active parts and equipment to which voltage is applied.
- In the event of a fault in the electrical power supply, switch the device off immediately.
- The device operates with liquids. For this reason, DIN EN IEC 62368/60950 must be observed when connecting the devices.

⚠ WARNING**Danger from unqualified personnel**



Possible consequence: fatal or serious injury and significant material damage.

- To ensure safe operation and prevent serious injury, the device must be installed by trained and authorized specialist personnel.
- Local installation regulations, general guidelines, technical data and construction regulations of the respective water or building authority as well as applicable national and local regulations must be observed.

NOTICE

The assembly accessories included in the scope of delivery must be used for installation.

8.1 Requirements with regard to the environment and installation location

 WARNING	
	<p>Danger caused by fire or explosive material Possible consequence: fatal or serious injury.</p> <ul style="list-style-type: none">• Do not use the device in environments where there are flammable gases, fumes or dust or conductive dust.• Smoking, fire, naked flames, welding, and work that may generate sparks are forbidden in the vicinity of the device.

The installation location must meet the following requirements:

- The installation location must not be accessible to the public.
- The installation location must be such that operation by unauthorized personnel is ruled out.
- The installation location must not be used as a permanent workplace.
- Protect the device against moisture, rain, frost, heat and direct sunlight.
- Do not install the device outdoors.
- Do not expose the device to strong vibration or impact, magnetic fields or electromagnetic radiation.
- Provide sufficient aeration and ventilation.

- Note the minimum ceiling height.
- The installation wall must be vertical, flat and stable.
- The device must be accessible and visible from the front and side for installation, operation and maintenance.
- Operating and ambient temperature must lie between 0 and +50 °C (32 ... 122 °F) (technical data).
- The air in the room must be non-condensing.
- The Electronics Module is not suitable for electrical connection with permanently installed cable conduits. If the cable glands do not meet local installation rules and regulations, these glands must be replaced with suitable ones.

8.1.1 Installation location for drinking water, industrial water and waste water

For problem-free mixing of the chlorine solution, the distance between chlorine addition and sample water take-off must be at least ten times the pipe diameter:

Example:	Pipe DN300 => 300 mm x 10 = 3000 mm => minimum distance = 3 m
----------	---

The time between chlorine addition and free over dosing is the total sampling time. It consists of the travel time between chlorine addition point and sample water take-off and the travel time between sample water take-off and measurement (sample water line to flow cell). Keep the sample water line to the flow cell as short as possible.

For longer required soak times, for example 5 to 15 minutes, a delay tank can be installed into the sample water line immediately before the flow cell.

Note that longer soak time prevents chlorine addition control based purely on excess chlorine. Instead, combined flow and excess chlorine dependent control must be used. This also applies to the use of chlorine, chlorine dioxide and ozone as disinfectant.

8.1.2 Installation site for swimming pool water

The sample water take-off point must be installed in the pool return line according to standards (see DIN 19643, DIN = German Industrial Norm). Make sure that the sample water take-off point is upstream of the flocculant station.

8.2 Installation the device

The Electronics Module and the Flow Cell Module can be installed using a top-hat rail or tallow-drop screws (wall installation). Several of those devices can be installed directly next to each other. A special variant is available for control cabinet mounting.

NOTICE

Install the Flow Cell Module to the left of the Electronics Module.

If the Electronics Module and the Flow Cell Module are mounted at separate locations, the sensor cable extensions with a maximum length of 30 m must be used.

Required material and tools:

- top-hat rail (optional)
- screws and dowels (assembly accessories)
- drill
- screwdriver

ATTENTION

Danger caused by incorrect mounting fixtures

Possible consequence: injury or significant material damage.

- Use the corresponding screws and dowels.
- Dowels and screws/tallow-drop screws for fixing to a solid wall are included in the scope of delivery.
- If the device is to be installed on a suitable light-weight wall, the corresponding mounting fixtures must be used. These mounting fixtures are not included in the scope of delivery!

8.2.1 Installation with top-hat rail

- 3 Secure the top-hat rail to a vertical, stable and flat solid wall using the dowels and screws supplied.
- 4 Hook the Electronics Module onto the top-hat rail so that it is flush at the right.
- 5 Hook the Flow Cell Module on the top-hat rail to the left of the Electronics Module.
- 6 Fasten the Electronics Module and the Flow Cell Module to the solid wall at the bottom by the brackets using dowels and screws.

8.2.2 Installation without top-hat rail (wall installation)

NOTICE

The dimensions for the drilling pattern can be found on the back of the plastic housing. Use the rear housing panel as a drilling template.

- 1 Secure the tallow-drop screws rail to a vertical, stable and flat solid wall using dowels.
- 2 Hook the electronics module and the flow cell module onto the tallow-drop screws.
- 3 Fasten the electronics module and the flow cell module to the solid wall at the bottom by the brackets using dowels and screws.

8.2.3 Installation drawings

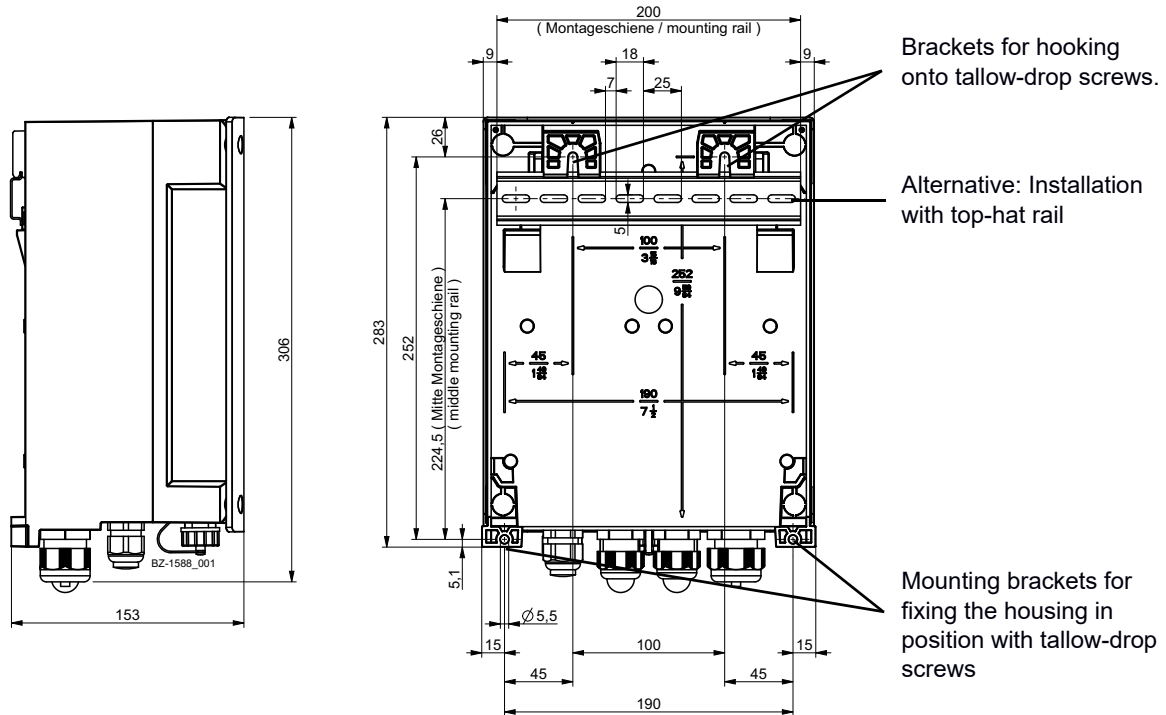

Fig. 12 Electronics Module

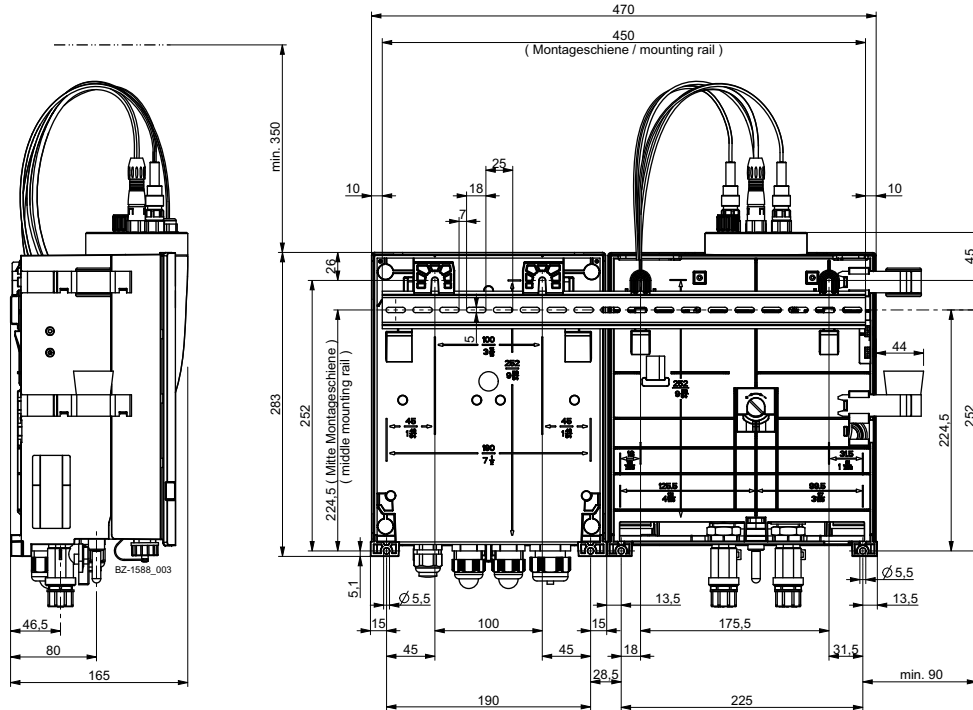

Fig. 13 Flow Cell Module and Electronics Module

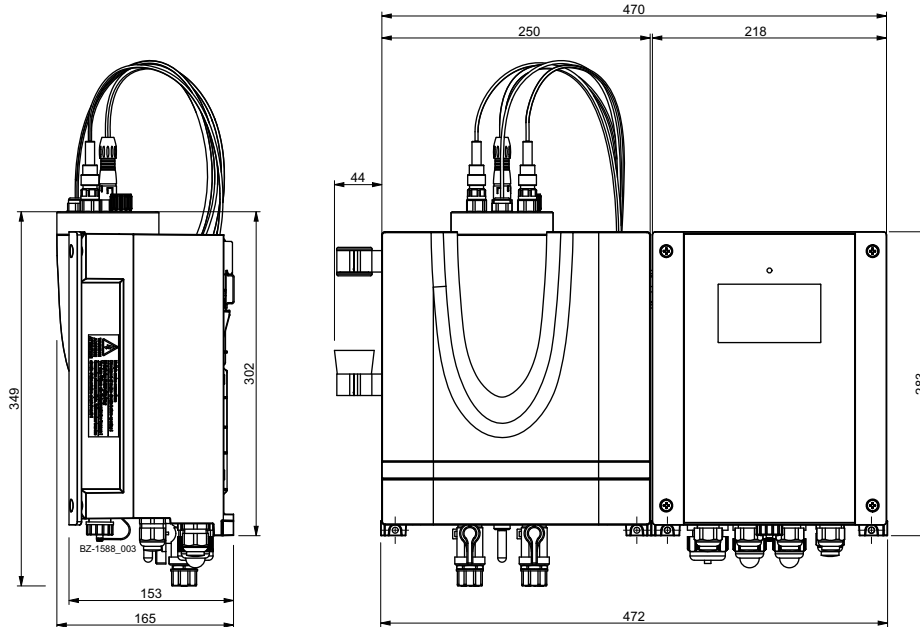

Fig. 14 Flow Cell Module and Electronics Module

8.3 Removing and fitting the housing cover

Removing

- 1 Release the four screws on the housing cover.
- 2 Carefully remove the housing cover.
- 3 Hook the housing cover into the brackets on the basic housing.

Fitting

- 1 Carefully unhook the housing cover from the brackets on the basic housing and fit it onto the basic housing.
- 2 Tighten the four housing screws by hand (to a maximum torque of $0.7 \text{ Nm} \pm 0.15 \text{ Nm}$).

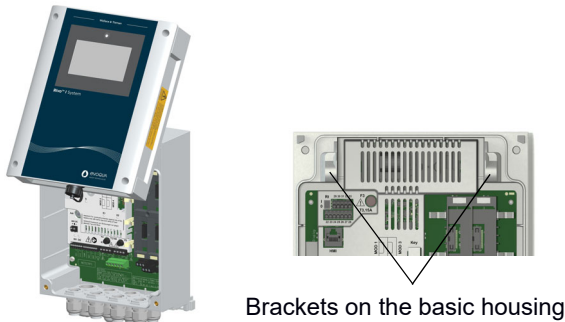

Fig. 15 Housing cover hooked on - brackets

8.4 Installation of Rivo™ Flex Mod Modules

CAUTION

Danger of damage to the Rivo™ Flex Mod Modules and the HMI

Possible consequence: Significant material damage.

- The Rivo™ Flex Mod Modules and the HMI must not be plugged in or unplugged with the power supply switched on.

- 1 Disconnect the Electronics Module from the power supply and check that it is de-energized.
- 2 Remove the housing cover of the Electronics Module.
- 3 Insert the Rivo™ Flex Mod Modules into the module slots provided and ensure that the module locking mechanism (blue) is engaged and pressed downward.

To dismantle the Rivo™ Flex Mod Module, first pull the module locking mechanism (blue) upwards and then remove the module.

Module 1, 2, 3 and 4 allow the installation of the following modules:

Module slot 1: Rivo™ Flex Mod (Measuring Module for Sensors)

Module slot 2: Rivo™ Flex Mod (Measuring Module for Sensors)

Module slot 3: Rivo™ Flex Mod 2Rel 2DO (Output Module)

Module slot 4: Rivo™ Flex Mod 2AO-mA (Output Module)

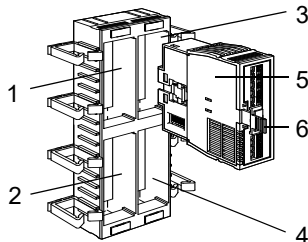

Fig. 16 Section, module slots

- 1 Module slot 1
- 2 Module slot 2
- 3 Module slot 3
- 4 Module slot 4
- 5 Rivo™ Flex Mod Module
- 6 Module locking mechanism (blue) - unlocking/locking

- 4 Route connection cables into the cable holder and into the housing through the cable glands.



Fig. 17 Section, cable connection

- 5 Tighten cable gland. Make sure that all cable glands are installed correctly.
- 6 Switch power supply back on.
- 7 When the device has booted, a scan must be carried out in order to transfer the new module configuration. To do this, open Setup - System settings - General and press the 'Scan' (hardware) button.
=> The device scans the changed module configuration and configures itself accordingly.

8.5 Remove the battery insulator

CAUTION**Danger due to battery insulator**

Possible consequence: Material damage

- When commissioning the HMI for the first time, the battery insulator of the lithium button cell must first be removed.

Procedure:

- 1 Fix the battery in the battery holder with a non-conductive pin and pull the battery insulator out to the left. Ensure that the battery is not pulled out at the same time.
- 2 The date and time must be set or checked during commissioning.

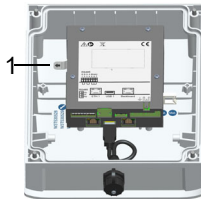

Fig. 18 HMI (housing cover)

- 1 Battery insulator



8.6 Connecting the Ethernet cable

NOTICE

- The cable glands on the Electronics Module are already fitted at the factory.
- Blind plugs are fitted in the cable glands at the factory. These must be removed during installation in order to install the corresponding cables.
- For more detailed information, please refer to the separate installation manual "Rivo™ communication interfaces". You can request this installation manual from us or download it from our homepage.

- 1 Route the Ethernet cable into the housing through the M25 cable gland. Only one Ethernet cable can be connected. Only one cable gland is provided and suitable for the insertion of Ethernet connectors (M25 left side).
- 2 The other cable glands can be used as required. Multiple sealing inserts (4x5 mm, 2x6 mm) are included with the accessories.
- 3 Plug the Ethernet cable into the HMI as shown in the wiring diagram.

8.7 Electrical installation

 DANGER	
	<p>Immediate danger caused by electric current Possible consequence: fatal or serious injury and significant material damage.</p> <ul style="list-style-type: none">• External voltages may still be connected even if the operating voltage is switched off.• The Electronics Module must be de-energized before opening it.• When connecting the Electronics Module to the power supply, a back-up fuse must be used in the mains supply line. The connection values must match the data on the type plate.

WARNING

Risk of injury and damage to the device!

Possible consequence: injury and significant material damage.

- Only trained and authorized electricians are permitted to install the Electronics Module and open the housing.
- The Electronics Module may only be put into operation when the housing is closed.
- Connect the Electronics Module in accordance with the wiring diagram and applicable local and national regulations.
- The Electronics Module is not equipped with a mains switch and is in operation as soon as the supply voltage is applied. For this reason, an external switch or circuit breaker with a clearly identifiable “Off” switch position is necessary.
- Line cross-section for the mains input side at least 0.75 mm² (AWG 18), on-site mains fuse 6 A with 100 to 240 V AC supply.
- When connecting system components (e.g. devices, motors, pumps) as well as when entering operating data, the system components must be switched off in order to prevent uncontrolled activation or incorrect operation.

WARNING

- If devices are connected to the internal power supply (e.g. dosing devices) or via fixed connection cables (e.g. connectors), the current consumption must not exceed the installed back-up fuse (max. 20A).
- Rivo™ Flex Modules and the HMI must not be plugged in or unplugged with the power supply switched on.
- The device operates with liquids. For this reason, DIN EN IEC 62368/60950 must be observed when connecting the devices.
- Avoid high temperatures at the terminals of the relays and the mains supply. Due to the high ambient temperatures at the terminals, connected cables must be designed as follows:
 - Ambient temperature <30°C:**
Cables heat-resistant up to at least 60°C
 - Ambient temperature <40°C:**
Cables heat-resistant up to at least 70°C
 - Ambient temperature >40°C:**
Cables heat-resistant up to at least 80°C

NOTICE

- The Electronics Module is not suitable for electrical connection with permanently installed cable conduits.
- If the cable glands do not meet local installation rules and regulations, these glands must be replaced with suitable ones.
- The Electronics Module is equipped with a flexible voltage supply input and accepts AC voltages from 100 to 240 volts. Take the power consumption into account when dimensioning.
- Note the correct polarity of the voltage connections and the correct dimensioning of the wire cross-sections.

Carry out electrical installation as follows:

- 1 Remove the housing cover of the Electronics Module.
- 2 Connect voltage supply in accordance with the wiring diagram.
- 3 Install optional Rivo™ Flex Mod Modules.
See chapter Installation "Installation of Rivo™ Flex Mod Modules".
- 4 Connect HMI/Rivo™ Backboard 4 in accordance with the wiring diagram. Make sure that all cable glands are installed correctly.
- 5 Connect optional Rivo™ Flex Mod Modules in accordance with the wiring diagram in chapter "wiring diagram".
- 6 Fit housing cover.
- 7 Then put the Electronics Module into operation.

NOTICE

If the module configuration is changed, a scan must be carried out. To do this, open Setup - System settings - General and press the 'Scan' (hardware) button.

8.8 Firmware update via USB interface

The firmware can be updated using a USB stick. The memory size must be at least as large as the firmware file.

NOTICE

The firmware file can be downloaded free of charge from our homepage.

You can read off the currently installed firmware version of the CPU in the menu under System Information.

Carry out the firmware update as follows:

- 1 Copy firmware file to the USB stick.
Do not use subdirectories!
- 2 Plug the USB stick into the USB socket (on the bottom of the device).
- 3 Open the Service-Center menu and click on the Update button. Follow the instructions on the display. The device executes a restart.
- 4 Firmware update starts. The LED (above the display) flashes during the firmware update.

- 5 When the firmware update is complete, the LED remains static.
- 6 Remove the USB stick.
- 7 Following a successful firmware update, check whether the new firmware version is displayed in the menu.
- 8 Check the settings, adjust if necessary.

8.9 RS485 interface (optional)

NOTICE

For more detailed information, please refer to the separate installation manual "Rivo™ communication interfaces". You can request this installation manual from us or download it from our homepage.

Install the Rivo™ Com-Board as follows:

- 1 Disconnect the Electronics Module from the power supply and check that it is de-energized.
- 2 Remove the housing cover of the Electronics Module.
- 3 Release the four screws on the metal cover of the HMI (Pos. 1).

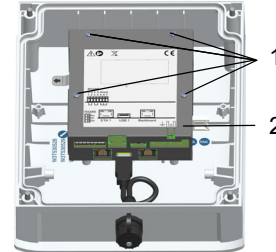

- 4 Carefully remove the metal cover of the HMI (Pos. 2).
- 5 Unscrew the four spacer bolts.
- 6 Grip the Rivo™ Com-Board carefully at the sides and insert the connector strip precisely into the terminal strips. Make sure that the connector strip is fitted correctly!
- 7 Tighten the four spacer bolts again by hand (to a maximum torque of $0.7 \text{ Nm} \pm 0.15 \text{ Nm}$).
- 8 Refit the metal cover and screw tight again using the four screws of the metal HMI cover.
- 9 Connect interface in accordance with the wiring diagram.
- 10 Activate terminating resistor when installing at the end of the bus.
- 11 Fit the housing cover again and tighten by hand (to a maximum torque of $0.7 \text{ Nm} \pm 0.15 \text{ Nm}$).
- 12 Reconnect the power supply.
- 13 Switch the Electronics Module on or reconnect the power supply.
- 14 Configure the interface.

9 START-UP

⚠ WARNING

Danger from unqualified personnel and incorrectly connected devices

Possible consequence: fatal or serious injury and significant material damage.

- To ensure safe and correct commissioning, knowledge of the operation, connected electrical load, measurement signals, cable assignment and fuse protection of the connected devices and machines and the relevant safety regulations is required.
- Startup of the electronic module must be performed by trained and authorized electricians.
- Incorrectly connected devices can be damaged, possibly irreparably, or cause faults in other equipment when they are switched on or in operation.
- Ensure that the measuring and control cables are not confused or make contact with one another.
- Never connect or disconnect any cables to which voltage is applied.

⚠ DANGER

Risk of injury or death!

Possible consequence: fatal or serious injury.

- The electronic module must not be operated with flammable liquids.

9.1 Initial commissioning and putting back into operation



Observe the instructions in the corresponding instruction manuals.

NOTICE

On delivery, the language setting of the Electronics Module is set to English.

Item	Work steps
1	Install the electronics module and the flow-through adapter.
2	Install optionalen fine filter (filter unit). Flow cell module only.
3	Install optional strainer.
4	Install optional pressure booster pump.
5	Install optional pressure reducing valve.
6	Install shut-off ball valve. Y-style Flow-through Assembly only.
7	Connect sample water inlet and outlet: <ul style="list-style-type: none"> • with rigid pipework • with hose connection

Item	Work steps
8	<p>Prepare DEPOLOX®-R:</p> <ul style="list-style-type: none"> • Remove the felt ring. • Remove and replace transport caps. • Fill electrode cleaning sand. <p>Prepare DEPOLOX® Pool-R:</p> <ul style="list-style-type: none"> • Fill electrode cleaning sand
9	Prepare sensors.
10	Install sensors in the flow-through adapter.
11	Connecting the sensor cable and connecting them with the electronics module.
12	Installing optional Modul Rivo™ Flex Mod Modules and Sensor Kit Rivo™ Sens/Mem.
13	Installing optional USB interface, extension board Rivo™ Com-Board and setting up Ethernet interface.
14	Checking whether sample water monitoring is active.
15	Integrating or activating safety shutdown.
16	Check whether monitoring of the circulation capacity or flow rate is installed.

Item	Work steps
17	<p>Start up the electronics module.</p> <ol style="list-style-type: none"> 1 Switch on power supply. 2 Select language (system menu - possible without password). 3 Log in and enter password protection (user administration). 4 Set date and time. 5 Enter the system name 6 Perform a scan: Check whether all installed Rivo™ I/O modules have been recognised. 7 Configure mA outputs (optional). 8 Configure signal input for flow rate. 9 If necessary, configure signal input for external dosing factor. 10 Configure measuring channel 1 and 2. 11 Controller settings for measuring channel 1 and 2. 12 If necessary, carry out the first servomotor calibration. 13 Configure digital inputs as required. 14 Configure alarms as required.

9 Start-up

EN Rivo™ I Municipal/Industrial

Item	Work steps
	15 Parameterise the interfaces. 16 In manual mode, check all dosing devices for correct function. 17 Test safety shutdowns. 18 Configure user administration.

10 SHUT-DOWN

WARNING

Danger from unqualified personnel

Possible consequence: fatal or serious injury and significant material damage.

- To ensure safe operation and prevent serious injury, the device must be taken out of operation by trained and authorized specialist personnel.

WARNING



Risk of injury due to chemicals

Dosing liquids are caustic and oxidizing.

Possible consequence: fatal or serious injury.

- Observe safety regulations and the prescribed protective clothing for handling chemicals.
- All instructions in the product data sheet for the dosing medium must be complied with.



See the corresponding instruction manuals of the flow-through adapter and sensors.

Procedure:

- 1 Disconnect the Electronics Module from the power supply.
- 2 Shut down the flow-through adapter.
- 3 Shut down the sensors.
- 4 Disconnect all cables from the Electronics Module.

11 OPERATION

11.1 Display and control elements

The display and control element is a colored graphic display with resistive touchscreen.

Alternatively, the Electronics Module can be controlled remotely via Ethernet connection with an Internet-capable device and standard browser. The user interface is identical to the physical operator interface on the device. In general, it is necessary to log in in order to make settings on the device or change the operation mode.

CAUTION

Damage to the touchscreen!

Touching the touchscreen with pointed or sharp objects or striking the touchscreen with hard objects will damage the glass surface and have a negative impact on the functionality.

Possible consequence: Significant material damage.

- Only touch the touchscreen with your finger or a pen (PDA pen for touch panels). The PDA pen is included in accessory set EM E10.

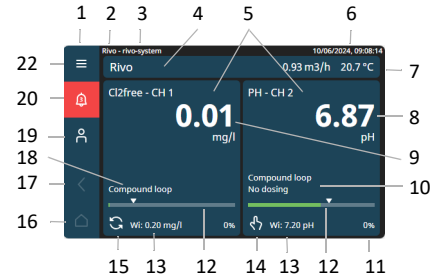







Fig. 19 Main menu (example)











- 1 Menu bar
- 2 Serie Rivo (Rivo cannot be changed)
- 3 Device name (individual entry)
- 4 Application bar (individual entry)
- 5 Measurement channel menu field (depending on Measuring Module, example Chlorine and pH)
- 6 Date, time
- 7 Temperature display and measurement unit (°C/°F and l/h)
- 8 e.g. pH value display (pH)
- 9 e.g. chlorine value display (mg/l)
- 10 PI controller - Compound loop, no dosing
- 11 Limit value exceeded
- 12 Bar graph display with indication of limit value
- 13 Display of digital inputs

- 14 Operation mode (example: manual mode)
- 15 Operation mode (example: auto mode)
- 16 Home key (main menu)
- 17 Back key
- 18 PI controller - Compound loop
- 19 Login
- 20 Alarms ACK
- 21 System menu

11.1.1 Icons















Some menus, icons, buttons or terms serve merely as displays, while others are assigned an underlying function (interactive menu navigation) or selection option. Values or terms can be entered, edited or saved in the input boxes.





Icon	Designation
	System menu
	Language (Icon under system menu)
	Alarms - ACK
	Log in
	Log out
	Log out

Icon	Designation
	Log in
	Apply
	Cancel
	Back button
	Home button
	Service-Center
	User administration selection
	Operating mode selection
	Operating mode "automatic mode" inactive/active Icon blue = "automatic mode" inactive Icon green = "automatic mode" active
	Operating mode "manual mode" inactive/active Icon blue = "manual mode" inactive Icon green = "manual mode" active
	Operating mode inaktiv/aktiv Icon blue = "Operating mode" inactive Icon green = "Operating mode" active

11 OPERATION

EN Rivo™ | Municipal/Industrial

Icon	Designation
	Reset button
	Alarm unwiderrufflich quittieren
	Alarm information
	Calibration
	Modul information
	Trend
	Hour display
<	Pre button
>	Button before
>	Projection button
	Values: selection
	Diagram view, CH 1
	Diagram view, CH 2
	Diagram view, Temperature
	Diagram view, Flow
	Diagram view, set-point
	Diagram view, controller output

Icon	Designation
	Sample water stop
	Setting
	Button Reset
	Service-Center

11.2 Password protection and user administration

NOTICE

Rules for password entry

Password must have at least eight characters. Upper case/lower case letters are allowed, as are figures and special characters.

11.2.1 Login - user administration (user level)

NOTICE



For initial configuration, the user must always have administrator rights. Further users can only be created via the administrator.

For access data, see label "Important System Information" - App Default (user/password).

Users log in with the corresponding rights (user levels) in the "Login" menu. Three user levels (roles) with different rights are available.

Role	Meaning
Operator (User)	Read rights for all settings Write access to: <ul style="list-style-type: none"> • Calibration • Simple setting • Operation modes
Administrator User: adminpassword: admin	Read rights and write access for all settings Write access to: <ul style="list-style-type: none"> • User assignment (User) • Configuration applications • Service-Center • Factory setting • Configuration, system type
Maintainer	Read rights for all settings Write access to: <ul style="list-style-type: none"> • All settings • Setup • Operation modes • Calibration

Procedure for setting up user levels:





- 1 Click the  symbol (system menu).
- 2 Click user administration.
- 3 Click the  symbol (create user).

Enter or select the following:

- Name:
- Password
- Description
- Roles



Click  to save.

Procedure for creating further users:

- 1 Click the  symbol (select user).
- 2 Enter user and password, and click  to log in.
- 3 Click the  symbol (system menu).
- 4 Click user administration.
- 5 Click the  symbol (create user) and create further user.

Click  to save.

Procedure for selecting a user:

- 1 Click the  symbol (select user).
- 2 Click the corresponding user.
- 3 Enter user name (User) and password.
- 4 Click  to log in.

11.3 Resetting a password

Passwords can be reset via the Service-Center (see chapter Service-Center).

NOTICE

Resetting access data

If you forget your access data, you can reset the system at any time using the Recovery Key. See label "Important System Information".

11.4 Application settings

Basic settings for the application are made in this menu.



Procedure:





- 1 Call up the Home menu (if applicable, click the Home key).
- 2 Click “Application setting” and make the corresponding settings.

	Input or selection options
Application settings	
<i>Application name</i>	<i>Input: individual</i>

11.5 Setting operation mode

Select the operation mode of the respective controllers as follows:

- 1 Call up the Home menu (if applicable, click the Home key).
- 2 Click measurement channel menu field.
- 3 Click  symbol or  symbol (operation mode). The corresponding operation mode is displayed.
- 4 Select operating mode.



 	<p>Automatic mode Automatic activation of dosing (symbol is green).</p>
 	<p>Manual mode Dosing is controlled manually (symbol is green).</p> <ul style="list-style-type: none"> • Option of manual dosing in % for an adjustable time. • After expiry of this time => change to the operation mode set under “next operation mode”. <ul style="list-style-type: none"> • With man. dosing time = 0, the running time man. dosing is unlimited.



	<p>Manual mode Dosing: display value in %</p> <ul style="list-style-type: none"> • Option of manual dosing in % for an adjustable time. • Dosing = 0.0 % The running time for manual dosing is unlimited. • After expiry of this time => change to the operation mode set under “next operation mode”. <p>Operation mode: Manual Dosing is controlled manually.</p>
---	--



11.6 Menu bar

The menu bar on the left of the display is visible on all menu levels. The system menu, alarm messages and the user login are opened via the menu bar. Return to the main menu for any menu level with the Home button. Press the arrow key to return to the previous level.

11.7 System menu

	Input or selection options
 System menu	
Menu 	<i>Language selection symbol - select the language: English GB – Deutsch – Français – English US</i>



	Input or selection options
User administration	
	<i>Create a new user.</i>
Name	<i>Input: User name</i>
Password	<i>Input: Password</i>
Description	<i>Input: z.B. Name, Position</i>
Roles	<i>Select: Operator - Administrator - Maintainer</i>
admin	 => <i>Edit the created users</i>



	Input or selection options
Setup	
System settings	
General	
Device name	<i>Entry of a customised device name or measuring point identifier</i>
Language	 <i>Select a language: English GB – Deutsch – Français – English US</i>
Service-Center	 => <i>Service-Center opens</i>
Hardware	 => <i>Perform a scan when changing the module configuration to accept the changed configuration.</i>
Time Config.	
NTP	<i>Activate/deactivate time synchronisation from the network. If OFF is selected, the time and date must be set manually. If ON is selected, the date and time are taken from the network.</i>
Timezone	<i>Select: Europa – Asien – America – Africa – Antarctica – Pacific – Australia – Atlantic – Indien</i>
Date	<i>Display: Year – Month – Day</i>
Time	<i>Display: Hours – Minutes</i>



Network Configuration	
DHCP	<i>Activate/deactivate</i>
IP address	<i>Input IP address If ON is selected, the IP address is automatically assigned by the network.</i>
Subnet mask	<i>Input Subnet Mask</i>
Gateway	<i>Input Gateway</i>
MAC address	<i>Display (automatic) Display of the physical hardware address of the device in the Ethernet.</i>
Global unit settings	
Global Unit Setting	<i>Units of Measurement: Metric – Imperial</i>
Temperature Unit	<i>Select: °C – °F</i>
Safety	
Secure calibration	<i>Activate/deactivate</i>

11 OPERATION

EN Rivo™ | Municipal/Industrial

Inputs / Outputs	
Relay outputs	<i>Depending on the configuration of the Rivo™ Flex Mod measuring modules</i>
e.g. Relay 1 <i>(depending on the configuration)</i>	 Module information: <i>Hardware address, Part Number, Serial number, Software version, Product name, Error Code, State, Relay-Out</i>
Label	<i>Input: individual</i>
Invers	<i>Select: ON – OFF</i>
Enable	<i>Select: ON – OFF</i>
Digital inputs	
Sample water stop	 Modul information: <i>Hardware address, Part Number, Serial number, Software version, Product name, Error Code, State, State</i>
Label	<i>Input: individual</i>
Controller	<i>Select: CH 1 – CH 2</i>
Input signal direction	<i>Select: Direct – Invers</i>
Debouncing	<i>Input: max. 1000 mS</i>
Sample water delay time	<i>Input: Time of day</i>

DI 2	 Modul information: <i>Hardware address, Part Number, Serial number, Software version, Product name, Error Code, State</i>
Label	<i>Input: individual</i>
Input signal direction	<i>Select: Direct - Invers</i>
Debouncing	<i>Input: max. 1000 mS</i>
Controller function	<i>Select: No function – Stop – Max. Dosing – Constant – 2xYout – Ignore external setpoint / dosing factor</i>
Controller	<i>Select: CH 1 – CH 2</i>
Analog outputs	<i>Depending on the configuration of the Rivo™ Flex Mod measuring modules</i>
e.g. mA output 2 <i>(depending on the configuration)</i>	 Modul information: <i>Hardware address, Part Number, Serial number, Software version, Product Name, Error Code</i>
Label	<i>Input: individual</i>
Range	<i>Select: 0 - 20 – 4 - 20</i>
Stop behavior	<i>Select: 0 mA – 4 mA – 10 mA – 12 mA – 20 mA – 22 mA – Hold last value</i>
Measurement	<i>Select: No selection – AI 2 – CH 1 – CH 2 – flow – Temperature</i>









Analog inputs	<i>Depending on the configuration of the Rivo™ Flex Mod measuring modules</i>
z.B. mA input 1 <i>(depending on the configuration)</i>	 Modul information: <i>Hardware address, Part Number, Serial number, Software version, Product Name, Error Code</i>
Demo Mode	<i>Select: Off – Demo Mode (Sinus)</i>
Label	<i>Input: individual</i>
Input signal	<i>Select: 0 - 20 mA – 4 - 20 mA</i>
Measurement filter	<i>Select: Off – Minimal – Low– Medium – Strong</i>
Input signal direction	<i>Select: Direct – Inverse</i>
Unit	<i>Input: individual</i>
Lower range	<i>Input: individual</i>
Uper range	<i>Input: individual</i>
Format	<i>Click: #0 – #0.0 – #0.00 – 0.000</i>
Limits	 <i>click</i>
AI 2 - Limits	
Limit value I	
Min	<i>Input</i>
Max	<i>Input</i>
Hysteresis	<i>Input</i>
Limit value II	
Min	<i>Input</i>
Max	<i>Input</i>
Hysteresis	<i>Input</i>

Communication	
Modbus TCP	
Enabled	<i>Activate/deactivate</i>
Codepage	<i>Select: UTF-8 – Windows-1252</i>
Port	<i>Input: individual</i>
Write protection	<i>Select: Off – On – On with Password</i>
Password timeout	<i>Input: ms</i>
RS485	
RS485	
Enabled	<i>Activate/deactivate</i>
Codepage	<i>Select: UTF-8 – Windows-1252</i>
Write protection	<i>Select: Off – on</i>
RS485 address	
Bus address 1	<i>Input: individual</i>
Bus address 2	<i>Input: individual</i>
Bus address 3	<i>Input: individual</i>

11 OPERATION



EN Rivo™ I Municipal/Industrial

	Input or selection options
Alarm Configuration	<i>Depending on the alarms</i>
e.g. Alarm 1	
Message	<i>Input</i>
Description	<i>Input</i>
Delay Time	<i>Input: Hours – Minutes – Seconds</i>
Alarm level	<i>Select: Warning – Error</i>
ACK Mode	<i>Select: None – Simple ACK – ACK with reset</i>
Assignment	<i>Select: Sample Water Stop – Digital In 2</i>
Relay Assignment	<i>Select: Rel1 BB00 S01 C01 – Rel2 BB00 S01 C02 – Rel3 BB00 S04 C02</i>

Trend	Input or selection options
	<i>Select: diagram view CH 1</i>
	<i>Select: diagram viewCH 2</i>
	<i>Select: diagram view temperature</i>
	<i>Select: diagram viewflow</i>
	<i>Sample water stop</i>
	<i>Select: 2h – 6h – 12h – 24h – 7d</i>
	<i>Back button/pre button for diagram view</i>
	<i>Projection butto for diagram view</i>
	<i>Select: Flow – Yout – DI1</i>



11 OPERATION

EN Rivo™ I Municipal/Industrial

	Input or selection options
Factory settings	
Reset system settings	
Reset	 <i>Reset the system settings.</i>
Reset application settings	
Reset	 <i>Reset the application settings</i>

	Input or selection options
System information	 <i>Icon to call the "service center" menu.</i>
Rivo OS	
Version	<i>Display the latest version</i>
Software versions	
Helio	<i>Display the latest version</i>
Helio Application	<i>Display the latest version</i>
IO-Connector	<i>Display the latest version</i>
SystemConfig	<i>Display the latest version</i>
Rivo	<i>Display the latest version</i>
ComGateway	<i>Display the latest version</i>
Service-Center	
Yaml information	
Yaml name	<i>Display the latest version</i>
Yaml version	<i>Display the latest version</i>
Yaml hash	<i>Display the latest version</i>
Serial number HMI	
Serial number Device	

11.7.1 Acknowledge/Messages

Display of error messages	
 Acknowledge (ACK)	
	<i>Acknowledge all alarms - All active alarm messages are irrevocably cancelled.</i>
	<i>Type Code Runtime Timestamp Acknowledged Description TODO: Empty description</i>

11.7.2 User log in/log out

NOTICE	
The currently logged in users are displayed in this menu.	

Log in	
 Log out	
User	<i>Input: User</i>
Password	<i>Input: Password</i>

11.8 Service-Center

System information can be called up and service functions carried out via the Service Center .

Only certain persons can access the Service Center by entering their user name and password.

Login is requested when a menu in the Service Center is opened. This login is not identical to the standard device login.



The standard device login on first opening the Service Center is:

User: service

Initial password: service

Following initial login, the user is prompted to change the password. The password must be saved in a safe place. If it is lost, it can be reset in the Service Center with the Recovery Key (see Chapter Resetting a password)



There are two ways to open the Service Center:

- 1 Switch the electronic module on, the device boots.  symbol appears briefly on the bottom right of the screen.
- 2 Click the  symbol. Service Center opens.
- 3 Select menus.

OR:

- 1 Click the  symbol (system menu).
- 2 Select System information menu.
- 3 Click Service Center.
- 4 Select menus.

 Interactive menu navigation.

	Input or selection options
	
Resource Monitor	<i>Display of the current utilisation of the CPU/memory</i>
View licenses	<i>Display of the open source licences used</i>
View journal logs	<i>Display journal</i>  Sort  Download log file
Device configuration	<i>Display and selection of the application or device configuration</i> <i>Depending on the version of the device, it is possible to switch from the higher version to the lower version of the application.</i> <i>Verfügbare Applikationen:</i> <i>2CH Analyser: 2 Channel measuring system without control function</i> <i>2CH Control PC: 2 Channel measuring system with control function</i> <i>Rivo I Control SC: Ratio control without measured value support</i>
Import/Export	<i>Menu for importing or exporting the device configuration of an identical device.</i>
Update	<i>Delete application data.</i>
System information	<i>Display:</i> <i>Rivo-OS version</i> <i>Service-Center version</i> <i>Serial number bb</i> <i>Serial number dev</i>

Reload UI	<i>Install new software/firmware. In this menu, a firmware file (ZIP file) can be loaded from a drive and the device update can be started.</i>
Clearup	<i>Return to main display</i>

11.9 Resetting a password in the Service-Center

It is possible to reset the device if the password is lost. To do this, you need the Recovery Key - Important Service Information (label included in the scope of delivery).

Procedure:

If an incorrect password is entered in the Service-Center, a "Recovery" button appears in the login window.

- 1 Enter the Recovery Key.
- 2 Click the "Recovery" button.
=> Device is reset. All passwords and settings are now deleted, and the device is reset to the factory settings.

11.10 Menu field measurement channel

The menu field Measurement channel shows the current measured value and the sensor signal. All settings relating to measurements, such as range, limit values and controller settings, must be made via this menu.

NOTICE

The measured values displayed depend on the various settings. Name can be entered individually. Depending on the user administration configuration and the currently registered users, the changes that can be made are limited. See Chapter 11.2.1 Login - user administration (user level).

Procedure for opening the menu field Measurement channel:

- 1 Call up the Home menu (if applicable, click the Home key).
- 2 Click the menu field of the measurement channel to be opened.
- 3 Click the corresponding symbol to make the desired settings.

 Interactive menu navigation.

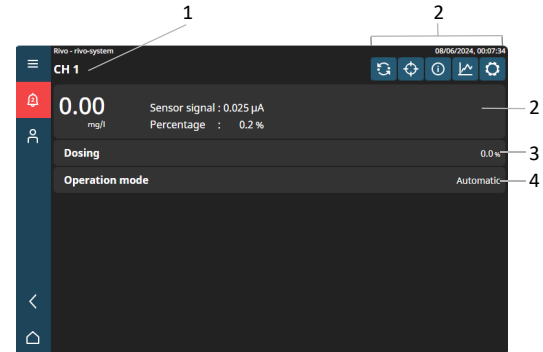



















Fig. 20 Example menu field Measurement channel

- 1 Display of measurement (name individual)
- 2 Function buttons (selection option via symbols)
- 3 Display of measured values - measured value - sensor signal - percentage (display only)
- 4 Dosing (display only)
- 5 Operation mode (display only)

11.10.1 Measuring channel- Measurement 1





	Input or selection options
Measurement 1 (Chlorine measurement as an example)	Display: mg/l, Sensor signal, Percentage, Dosing, Operation mode  Selection via icon: Operation mode, Calibration, Module information, Trend, Settings
 Measurement 1 - Operation mode	
Operation mode/ Next operation mode	Display operation mode
	Icon blue = Automatic mode inactive
	Icon green = Automatic mode active
	Icon blue = Manual mode inactive
	Icon green = Manual mode active
Bumpless-Transfer	Select: Aus – Einmalig – Dauerhaft
Setpoint	Input: mg/l (max. 1 mg/l)
Dosing time (only manual mode)	Input: Hour– Minutes – Seconds
Dosing time (only manual mode)	Input: %
 CH 1 - Calibration	Display: mg/l, Cell signal, Zero point, Span  Click => Are you sure you want to delete the calibration? => Cancel/Confirm  Click => CH 1 - Calibration archive (Date, Zero point, Span)
Zero point	Automatic display μA  Switch off the sample water supply
Span	Automatic display $\mu\text{A}/\text{mg/l}$



 CH 1 - Module information	<i>Display: Hardware address, Part number, Serial number, Software version, Product name, Error Code</i>
 Trend	<i>Display: Trend (see explanation System menu - Trend)</i>
 CH 1 - Settings	
Measurement	
CH 1 - Measurement	
Demo Mode	<i>Select: Off - Demo Mode (Sinus)</i>
Label	<i>Input: individual</i>
Range	<i>Select: 0 - 20 mA – 0 - 0,50 – 0 - 1,0 – 0 - 2,0 – 0 - 3,00 – 0 - 5,00 – 0 - 10,0 – 0 - 20,0 – 0..50,0</i>
Unit	<i>Select: mg/l – µg/l</i>
Measurement filter	<i>Select: Off - Minimal – Low– Medium – Strong</i>
Sensor settings	
CH1 - Sensor settings	
Sensor typ	<i>Select: Cl2frei – Cl++ – KMnO4 – O3 – ClO2 – Br – NH4+ – Free selection</i>
Sensortyp Typ Def.	<i>Input: individual</i>
Sensor	<i>Select: Depolox 5 – Rod electrode – Membrane FC – Membrane TC – Membrane CD – Membran eOZ</i>
µA Range	<i>Select: 1000 µA – 100 µA – 10 µA – Auto</i>
Upot	<i>Input: mV (max. 1000)</i>

Limits	
CH1 - Limit values	
Limit value I	
Min	<i>Input: mg/l</i>  <i>click=> Delete limit value</i>
Max	<i>Input: mg/l</i>  <i>click=> Delete limit value</i>
Hysteresis	<i>Input: mg/l</i>
Limit value II	
Min	<i>Input: mg/l</i>  <i>click=> Delete limit value</i>
Max	<i>Input: mg/l</i>  <i>click=> Delete limit value</i>
Hysteresis	<i>Input: mg/l</i>

11 OPERATION

EN Rivo™ I Municipal/Industrial

Dosing	
CH 1 - Dosing	 => CH 1 - Dosing information (Dosing quantity, Average dosage, Max. dosing, Min. dosing)
Actuator	Select: Positioner w. Ym – Pump 2P – Analog output 2P
Settings actuator	
CH 1 - Stellmotor mit Ym	 => CH 1 - Positioner w. Ym – information (Ty, Calibration start value, Calibration end value, Feedback, Dead time same direction, Dead time direction change, Feedback delay)
Calibration positoner	Start – Cancel
Feedback Threshold	Input
Dosing agent settings	
CH 1 - Dosing agent settings	 => Display: Dosing quantity, Average dosage, Max. dosing, Min. dosiing
Dosier Statistics	Reset
Unit dosing performance	Input
Time base dosing performance	Select: Min. – h – Day
Max. rate	Input
Linearization	
CH 1 - Linearization	
Dosing	Input: current dosing

Linearization point 0%	<i>Input</i>  => Delete linearization point
Linearization point 10%	
Linearization point 20%	
Linearization point 30%	
Linearization point 40%	
Linearization point 50%	<i>Input</i>  => Delete linearization point
Linearization point 60%	
Linearization point 70%	
Linearization point 80%	
Linearization point 90%	
Linearization point 100%	

Controller	
CH 1 - Controller	
Bumpless-Transfer	Select: Off – Once – Permanent
Feed delay time	Select: Hours – Minutes – Seconds
Safety MAN. Mode	Activate/deactivate
Controller settings	>
CH 1 - Controller settings	<p>⊙ => Display: P-Part, I-Part, Max. PID output, Uncorrected PID output, Controller state, Dosing factors</p> <p>Dosing factors > => Display: Flow – Factor – Percentage count – Count</p>
Source setpoint	Select: Internal – AI 2
Setpoint	Input: individual
Tconst	Input: Hours – Minutes – Seconds
Tvar	Input: Hours – Minutes – Seconds
Max.lin.correction	Input: %
Control factor	Input: individual
Control direction inverse	Activate/deactivate
Flow jum threshold	Input: min. 5 % / max. 100 %
Max	Input: max. 100 %
Min	Input: max. 100 %
Switch to proportional control	> => activate/deactivate

12 CALIBRATION

NOTICE

All installed measurements must be checked regularly. Test and calibration intervals must be adhered to in accordance with the applicable regulations.

To prevent impermissible control signals from being output during calibration, the controller outputs are kept constant during the calibration process.

A "Secure calibration" function is available for calibrating the sensors. If activated, this prevents the uncontrolled dosing of chemicals and switches off the dosing if the calibration menus are permanently active.

To find out how often you must calibrate, refer to chapter "Maintenance Schedules".

12.1 Temperature calibration

The temperature is calibrated via the "Application Bar". The temperature calibration can be carried out in the Temperature menu. If there is a deviation between the comparison measurement and the measured value display on the Electronics Module.

 It is possible to select °C or °F in the „Temp. unit“ menu. The required temperature input can be selected or switched off in the „Temp. sensor“ menu.

12.2 Chlorine calibration

Chlorine calibration of 3-electrode measuring cell (DEPOLOX®-R) and 3-electrode single-rod measuring sequence Chlorine (DEPOLOX® Pool-R)

Calibration of the 3-electrode measuring cell for Cl_2 , KMnO_4 , O_3 , ClO_2 and Cl_2^{++} (pH-compensated).



The sequence must not be reversed.

Before Cl_2^{++} calibration, it must be ensured that the pH measurement is calibrated correctly.

When calibrating the 3-electrode measuring cell, first carry out a zero point calibration and then a measured value calibration (DPD).

The calibration process is nearly the same for chlorine, chlorine dioxide, ozone and potassium permanganate.

The difference lies in the fact that some of the reagents are measured with a photometer and others with a colour meter.

Zero point calibration

- 1 Starting from the basic display in the main menu select the "Calibration" menu.
- 2 Select the measurement to be calibrated from the menu, e.g. Cl_2 free.
- 3 Select the "Cal. zero" parameter and follow the instructions on the display.

Zero point calibration with disinfectant-free water

- 4 If disinfectant-free water (e.g. by switching off the dosing system) is available, zero point calibration can be performed with it. In this case, switch off the dosing and use disinfectant-free water. Do not close the sample water inlet during zero point calibration.

Measurement value calibration (DPD)

- 5 After zero point calibration, wait at least two minutes.
- 6 Select the "Span" parameter and determine the content of free chlorine, ozone, chlorine dioxide or potassium permanganate, e.g. using a photometer. Follow the instructions on the display.

 In the DPD calibration of the Cl₂++ measurement the calibration value should be greater or equal to 25 % of the measuring range.

12.3 Membrane sensors calibration

Calibration is nearly identical for all membrane sensors. The difference lies in the fact that some of the chemicals are measured manually with a photometer and others with a colour meter.

A 1-point calibration is available to calibrate the total chlorine measurement and the combined chlorine measurement.

Either the total chlorine or the combined chlorine must be calibrated.

For the selective ozone, chlorine dioxide and free chlorine measurements, 1-point or 2-point can be selected in the calibration menu of the "Calibration mode". 2-point calibration provides the option to compensate for possible measuring cell zero point offsets.

Total chlorine

The span calibration must be performed for the total chlorine calibration. Proceed as follows:

- 1 Open the calibration menu.
- 2 Select "Span Calibration" and follow the instructions on the display.

Combined chlorine (optional)

When calibrating the combined chlorine measurement, the value of the free chlorine is also taken into account, so it must be ensured that the free chlorine display is correctly calibrated.

The value determined by the comparison measurement can then be calibrated according to the instructions on the display.

Zero point calibration for ozone, chloride dioxide, Cl₂ free (M)

Nullpunktkalibrierung bei 2-Punkt-Kalibrierung



Instead of the zero point, a DPD value determined by comparative measurement can also be calibrated.

DPD calibration using 1-point and 2-point calibration for Ozone, Chlorine dioxide and Chlorine

For calibration, determine the content of free chlorine, ozone, chlorine dioxide, e.g. with a photometer and follow the instructions on the display.

12.4 pH calibration

NOTICE

During pH calibration the buffer solution and the sample water should have the same temperature. If there is a difference in temperature of > 5 °C, first enter the temperature of the buffer solution in the menu "Calibration" - "pH" under "Cal. at temp."

pH-7 alignment

- 1 Starting from the basic display in the main menu select the "Calibration" menu and follow the instructions on the display under pH7 calibration.

Slope alignment

- 2 Wash the sensor in distilled water to prevent carry-over of the buffer solution.
- 3 Select the parameter "Cal. pH X".



If buffer solutions other than those stated are used, the pH value of the buffer solution must be lower than pH 6 or higher than pH 8.

- 4 Dip the pH sensor at least 2 cm deep into the buffer solution until the indicated pH value remains constant.

pH correction

If external influences result in a constant difference between the displayed pH value and a pH value measured manually, this difference can be compensated.

- 1 Starting from the basic display, from the main menu, select the „Calibration“.
- 2 Select the parameter "Offset" and follow the instructions on the display.

 The offset is deleted each time a new pH-7 alignment or span alignment is performed.

12.5 Redox calibration (mV)

 Redox sensors have long running-in times. After calibration with a buffer solution, it can therefore take several hours until the value has stabilized.

- 1 Starting from the basic display, from the main menu, select the „Calibration“ menu.
- 2 Select menu item "ORP" and follow the instructions on the display.

12.6 Conductivity calibration

 The conductivity sensor has an integrated temperature sensor and therefore an automatic temperature compensation feature.

In the conductivity calibration menu, the temperature of the temperature sensor in the conductivity sensor can be adapted with the parameter "Cal. temperature" to a comparative measurement.

- 1 Starting from the basic display, from the main menu, select the „Calibration“ menu and follow the instructions on the display.

Depending on the measuring range:

- 600 µS/cm calibration solution for a measuring range of 2500 µS/cm
- 60 mS/cm calibration solution for all mS/cm measuring ranges

12.7 Fluoride calibration

The fluoride measurement is calibrated at 2 points, which should be as far from each other as possible, but within the measurement range. The lower value must be calibrated with a lower fluoride concentration than the upper value, e.g. lower value 0.20 mg/l and upper value 2.00 mg/l. Calibration solutions for 0.20 mg/l, 2.00 mg/l and 100 mg/l are available.

 Before use, the electrode must be placed in a 100 mg/l fluoride solution at pH 7 for approx. 24 hours. This is necessary to guarantee that the electrode functions properly.

- 1 Starting from the basic display, from the main menu, select the „Calibration“ menu and follow the instructions on the display.

Fluoride correction

If external influences result in a constant difference between the displayed value and a fluoride value measured manually, this difference can be compensated.

- 1 Starting from the basic display, from the main menu, select the „Calibration“ menu and follow the instructions on the display.

 The offset correction is deleted at every new fluoride calibration or slope alignment.

13 SYSTEM MESSAGES



There are error messages, warnings, information and status messages.

If it is not possible to remedy the cause of the system messages yourself, please contact your service contractor.

Explanation of the field "System":

Error code in the system	Designation
Analyser	Elektronics Module Rivo™ I Municipal/Industrial (Mod. E10) Analyser
PC	Elektronics Module Rivo™ I Municipal/Industrial PC (Mod. E10) Analyser and controll functions

Error Code	System	Level	ACK	Cause	Remedy
E-COM-100					
E-COM-101					
E-COM-102					
E-IOC-101	Analyzer, PC	Error		Internal memory inconsistency.	Please contact service. Update software.
E-IOC-102	Analyzer, PC	Warning		Hardware configuration has changed due to the removal or addition of modules.	Check the Hardware. Run hardware scan. Setup->System->General

E-IOC-103	Analyzer, PC	Error		Hardware or electronic error in the Indicated module.	Please contact service.
E-IOC-104	Analyzer, PC	Error		Unknown hardware. Hardware could not be identified.	Please contact service.
E-IOC-105	Analyzer, PC	Error		Communication error in the indicated module.	Check the Hardware. Please contact service.
E-IOC-106	Analyzer, PC	Error			
E-IOC-107	Analyzer, PC	Info	YES	Firmware upgrade successfully performed on the indicated module.	Message can be deleted by ACK.
E-IOC-108	Analyzer, PC	Error		Firmware upgrade successfully performed on the indicated module.	Please contact service.
E-RIV-100	Analyzer, PC	Error		Sample water flow rate too low, dirt strainer dirty, ball valve sample water inlet or sample water outlet closed, dirt in the inlet, flow control valve or ball check valve housing.	Open ball valves, clean strainer, remove dirt.
E-RIV-101	PC	Warning		The selected dosing unit is not compatible with the set controller type.	Adjust the dosing unit settings.
E-RIV-102	Analyzer, PC			Configured alarm was triggered.	
E-RIV-103	Analyzer, PC	Error		A required hardware module is not available.	Retrofit the appropriate hardware and perform a hardware scan, or select a suitable application.

13 System messages

EN Rivo™ I Municipal/Industrial

E-RIV-104	Analyzer, PC	Warning		Maintenance interval for calibrating the indicated measurement.	Kalibrierung durchführen.
E-RIV-105				Maintenance interval no further specified.	
E-RIV-106	PC	Error		General runtime error.	Check the actuator feedback of the servomotor.
				Possible causes: Missing or incorrect actuator feedback.. Setting wheel unlocked Electronics error	Check the connections. Lock the adjusting wheel.
E-RIV-107	PC	Error		Servomotor calibration error	Check the actuator feedback of the servomotor.
E-RIV-108	PC	Info		Only for servomotors without feedback. A reference run is performed for zero adjustment.	
E-RIV-109	SC,PC	Info		Self-calibration of the servomotor is performed.	Wait until the process is completed.
E-RIV-110	Analyzer, PC	Error		Configuration error in the relay output.	Adjust the settings.
E-RIV-111	Analyzer, PC	Error		Input signal outside of measurable range.	Check input signal and wiring.
E-RIV-112	Analyzer, PC	Error		Input signal outside of measurable range.	Check input signal and wiring.

E-RIV-113	Analyzer, PC	Error		Hardware or electronics error in the Indicated module..	Please contact service.
E-RIV-114	Analyzer, PC	Error		Missing factory calibration in the Indicated module.	Please contact service.
E-RIV-115	Analyzer, PC	Error		Cell error, sensor defective.	Check the sensor, replace if necessary.
E-RIV-116	Analyzer, PC	Info		Communication error in the indicated module.	Please contact service.
E-RIV-117	Analyzer, PC	Error		Hardware or electronic error in the Indicated module.	Please contact service.
E-RIV-118	Analyzer, PC	Info		Communication error in the indicated module.	Please contact service.
E-RIV-119	Analyzer, PC	Error		Input signal outside of measurable range.	Check input signal and wiring.
E-RIV-120	Analyzer, PC	Error		Input signal outside of measurable range.	Check input signal and wiring.
E-RIV-121	Analyzer, PC	Error		Hardware or electronic error in the Indicated module.	Please contact service.
E-RIV-122	Analyzer, PC	Error		Missing factory calibration in the Indicated module.	Please contact service.
E-RIV-123	Analyzer, PC	Info		Communication error in the indicated module.	Please contact service.

13 System messages

EN Rivo™ I Municipal/Industrial

E-RIV-124	Analyzer, PC	Error		Input signal outside of valid range.	Check input signal and wiring.
	Analyzer, PC			Connecting cable is interrupted.	Falls der Eingang nicht benötigt wird, kann er deaktiviert werden.
E-RIV-125	Analyzer, PC	Error		Input signal outside of valid range.	Check input signal and wiring.
				Incorrect signal source.	Check the signal source.
E-RIV-126	PC	Error		Input signal outside of measurable range.	Check the input signal and wiring.
E-RIV-127	PC	Error		Input signal outside of measurable range.	Check the input signal and wiring.
E-RIV-128	PC	Error		Hardware or electronic error in the Indicated module.	Please contact service.
E-RIV-129	PC	Error		Missing factory calibration in the Indicated module.	Please contact service.
E-RIV-130	PC	Error		Actuator was unlocked.	
E-RIV-131	PC	Info		Communication error in the indicated module.	Please contact service.
E-RIV-132	Analyzer, PC	Error		Input signal outside of measurable range.	Check the input signal and wiring.
E-RIV-133	Analyzer, PC	Error		Input signal outside of measurable range.	Check the input signal and wiring.
E-RIV-134	Analyzer, PC	Error		Hardware or electronic error in the Indicated module.	Please contact service.

E-RIV-135	Analyzer, PC	Error		Missing factory calibration in the Indicated module.	Please contact service.
E-RIV-136	Analyzer, PC	Info		Communication error in the indicated module.	Please contact service.
E-RIV-137	Analyzer, PC	Error		Input signal outside of measurable range.	Check input signal and wiring.
E-RIV-138	Analyzer, PC	Error		Input signal outside of measurable range.	Check input signal and wiring.
E-RIV-139	Analyzer, PC	Error		Hardware or electronic error in the Indicated module.	Please contact service.
E-RIV-140	Analyzer, PC	Error		Missing factory calibration in the Indicated module	Please contact service.
E-RIV-141	Analyzer, PC	Error		No sensor signal.	
E-RIV-143	Analyzer, PC	Info		Communication error in the indicated module.	Please contact service.
E-RIV-144	Analyzer, PC	Error		Load error The mA output cannot drive its mA output current through the connected current loop (max. 500 Ohm at 20 mA).	Check the signal cable for interruption. If the output is not required, it can be deactivated.
E-RIV-145	Analyzer, PC	Error		Hardware or electronic error in the Indicated module.	Please contact service.
E-RIV-146	Analyzer, PC	Error		Missing factory calibration in the Indicated module	Please contact service.

13 System messages

EN Rivo™ I Municipal/Industrial

E-RIV-147	Analyzer, PC	Info	YES	Indicates that a calibration is in progress	
E-RIV-148	Analyzer, PC	Warning		Slope warning. The current difference falls below 1µA/mgl.	Check whether there are any air bubbles on the membrane sensor and remove them if necessary. Carry out maintenance on membrane sensors - replace electrolyte/membrane cap. Clean 3-electrode measuring cell, replace cleaning sand.
E-RIV-149	PC	Error		Hardware or electronic error in the Indicated module.	Please contact service.
E-RIV-151	Analyzer, PC	Info	YES	Note for a successful upgrade. Data was successfully migrated.	Message can be deleted by ACK.
E-RIV-152	Analyzer, PC	Info	YES		
E-RIV-153	Analyzer, PC	Error	YES	Only if the "Safe calibration" function is activated.	If necessary, reinsert the sensors into the Flow-through Adapter.
				The calibration process was ended after the timeout.	Press the 'ACK' button to continue the control process.
				Control was stopped for safety reasons.	
E-RIV-154	Analyzer, PC	Info	YES	Calibration data are outside the valid range.	

E-RIV-155	Analyzer, PC	Info	YES	Calibration not accepted.	Check the chlorine sensor. Clean the electrodes Check the pH value of the water (< pH 8).
				Cause zero point: Zero current of the sensor > +5 µA or < -5 µA	
				Cause DPD: Minimum current difference was not reached 10 µA 0.04 µA/mg/l 100 µA 0.4 µA/mg/l 1000 µA 4.0 µA/mg/l	
E-RIV-156	Analyzer, PC	Info	YES	Calibration data are outside the valid range.	
E-RIV-157	Analyzer, PC	Info	YES	Calibration data are outside the valid range.	
E-RIV-158	Analyzer, PC	Info	YES	Calibration data are outside the valid range.	
E-RIV-159	Analyzer, PC	Info	YES	Calibration data are outside the valid range.	
E-RIV-160	Analyzer, PC	Warning			
E-RIV-161	Analyzer, PC	Warning			
E-RIV-162	Analyzer, PC	Warning			

13 System messages

EN Rivo™ I Municipal/Industrial

E-SYS-101					
E-SYS-102					
E-SYS-103					
E-SYS-104					
E-SYS-105					

14 TROUBLESHOOTING



If it is not possible to remedy the fault or error yourself, please contact your service contractor.

Faults	Cause	Remedy
No indication on device.	No power supply.	External switch or fuse on.
	Device fuse defective.	Check the power supply and replace fuse. (Electrician)
	Housing cover is not fitted correctly.	Check and, if necessary, fit the housing cover correctly (cable possibly trapped).
Positioner/pump does not work.	Positioner in manual mode.	Engage manual knob.
	Dosing device selected incorrectly.	Select correct dosing device.
	Positioner/pump incorrectly connected.	Connect positioner/pump correctly. (Electrician)
	Relay defective.	Check. (Electrician)
Positioner runs in wrong direction.	Positioner incorrectly connected.	Correct connections. (Electrician)
Positioner closes.	Positioner feedback interrupted.	Correct connections. (Electrician)
Digital inputs without function.	Digital inputs not activated.	Activate digital inputs.

15 MAINTENANCE

 WARNING
<p>Danger from unqualified personnel Possible consequence: fatal or serious injury and significant material damage.</p> <ul style="list-style-type: none"> • To ensure safe operation and prevent serious injury, the device must be serviced by trained and authorized specialist personnel. • Observe the specified maintenance intervals. • Adhere to the applicable standards and national and regional regulations.

15.1 Maintenance intervals

Depending on the specifications, comparative measurements must be carried out several times a day or once a week using a test device. In the event of deviations, the measured values or sensors must be calibrated (see chapter Calibration).

Replace the battery of the Electronics Module after 5 years.

Article number	Designation
W3T570783	Battery, Electronics Module

15.2 Replace battery

The battery is required for the real time clock in the event of a power failure. If the time is not correct or if time-controlled functions show faulty behavior, the battery must be changed. Replace the battery after 5 years at the latest.

- 1 Disconnect the electronic module from the power supply and check that it is de-energized.
- 2 Remove the housing cover of the electronic module.
- 3 Unscrew the metal cover on the HMI.
- 4 Remove the battery from the HMI holder.
- 5 Insert the new battery, type CR1632. Observe the correct polarity!
- 6 Re-attach the metal cover to the HMI.
- 7 Fit housing cover.
- 8 Turn the power supply on.
- 9 Set the date and time. No further settings are required.

15.3 Replacing the fuses on the CPU board

 See Chapter Design.

The mains input and all relays are protected by fuses of type TR5. 3.15 A (slow-blow) fuses are used for the relays and 1.6 A (slow-blow) fuses for the mains input. Spare fuses are included with the accessories.

- 1 Disconnect the Electronics Module from the power supply and check that it is de-energized.
- 2 Remove the housing cover of the Electronics Module.
- 3 Pull the defective fuse out of the fuse holder and insert the new fuse. Make sure the rated data match!
- 4 Fit housing cover.
- 5 Turn the power supply on.

15.4 Cleaning

CAUTION

Danger caused by incorrect cleaning agent

The use of non-approved cleaning agents can damage housings, seals, cables and the touchscreen.

Possible consequence: Serious material damage.

- Never use corrosive cleaning agents (e.g. isopropyl alcohol, spirit, scouring agents)!

15.4.1 Cleaning the housing

Clean housing, seals and cables with a moist cloth, if necessary with the addition of a commercially available neutral cleaning agent, and then dry them.

15.4.2 Cleaning the display

Clean the touchscreen with a non-linting microfiber cloth. To remove heavy soiling, moisten a corner of the cloth and wipe the touchscreen. Then dry immediately using the dry side of the cloth.

16 DISMANTLING AND DISPOSAL

WARNING

Danger from unqualified personnel

Possible consequence: fatal or serious injury and significant material damage.

- To ensure safe operation and to avoid serious personal injury, the appliance may only be dismantled and disposed of by trained and authorized specialist personnel.

16.1 Dismantling

- 1 Prior to disposal, delete any personal data stored on the old equipment.
- 2 De-energize the device.
- 3 Dismantle and dispose of the device properly and recycle raw materials.

16.2 Disposal

16.2.1 General information

Ensure safe and environment-friendly disposal of old equipment, replacement parts, auxiliary materials, chemicals and their containers. Disposal must be effected in compliance with local, regional, national and international regulations.

NOTICE



The symbol with the crossed-out garbage can indicates that the product - electrical and electronic equipment, batteries and storage batteries - must not be disposed of with household waste. At the end of its service life, the product must be disposed of appropriately or recycled. The statutory requirements of the country in which the product is put into use apply here.

16.2.2 Used electrical/electronic equipment

Electrical or electronic equipment is labeled with the symbol showing a crossed-out garbage can and must not be disposed of with household waste, but must be collected and disposed of separately. The statutory requirements of the country in which the product is put into use apply.

Before handover to a collection point, old batteries, storage batteries and lamps must be removed from the old equipment and turned over to the corresponding collection points.

Where such central collection systems are not available, used equipment purchased from us can be returned to us.

Further details can be found on the official website of Evoqua Water Technologies GmbH.

- Scan the QR code.
- OR enter the following link in your browser:
<http://qr.evoqua.com/bdYxgi>



16.2.3 Used batteries and used storage batteries

Batteries and storage batteries are labeled with the symbol showing a crossed-out garbage can. Where, for technical reasons, it is not possible to label the batteries themselves, the symbol may be printed on the packaging. Used batteries and used storage batteries must not be disposed of with household waste, but must be collected and disposed of separately. The statutory requirements of the country in which the product is put into use apply. If necessary, contact your regional or local authorities for details of collection points and options for separating and collecting waste.

DANGER

Risk of injury caused by damaged batteries and storage batteries!

Possible consequence: fatal or serious injury and significant material damage

- Short-circuiting, for example caused by external contact with the battery poles (metal on metal), may cause fire or an explosion. Prior to disposal, cover the poles of batteries and storage batteries with masking tape to prevent an external short-circuit.
- There is an increased hazard if batteries are damaged or leak. Avoid touching 'greasy' or leaking batteries with your bare hands wherever possible. Wash your hands thoroughly if they have come into contact with leaking components.
- Observe the respective safety instructions, in particular in the case of batteries and storage batteries containing lithium.

17 SPARE PARTS, ACCESSORIES, RETROFIT KITS

⚠ WARNING

Danger from incorrect spare parts, accessories and retrofit kits

There is a risk of malfunction or damage to the appliance if unauthorized spare parts, accessories and retrofit kits are used.

Possible consequence: fatal or serious injury and significant material damage.

- For reasons of safety, only use original spare parts, accessories and retrofit kits. If required, please contact our customer service or visit our e-commerce store.

17.1 Spare parts

Article number	Designation
W3T601620	Backboard Rivo™ Board 4
W3T582385	Mains fuse 230V, TR5, T2A
W2T839300	Mains fuse 24V, relay, TR5, T3, 15A
W2T555401	HMI battery, CR1632
W3T604350	Operating front panel 4 RT Rivo™ I
W3T587694	Patch cable to the display
W3T587503	HMI protective grounding
W3T570786	Accessory set EM E10 (incl. PDA pen for touch panel W3T160886)

17.1.1 Modules for connection to sensors

Article number	Designation
W3T557878	Rivo™ Flex Mod Dis
W3T557901	Rivo™ Flex Mod mV
W3T557902	Rivo™ Flex Mod pH
W3T557903	Rivo™ Flex Mod Fluoride
W3T557907	Rivo™ Flex Mod Con

17.2 Optional accessories

Article number	Designation
W3T557914	Rivo™ Flex Mod 2Rel-2DO Relay module for activation of dosing outputs and alarms
W3T557912	Rivo™ Flex Mod 2AO-mA (mA signal output module, 2-channel)
W3T583003	Rivo™ Com-Board 485

18 WIRING DIAGRAM

WBE2150 V: 01-0524

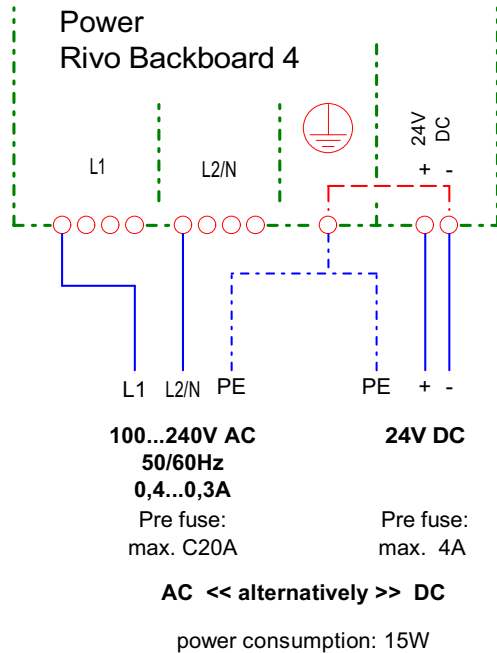

Note

With mains supply 100...240V AC the additional terminals L1 and N/L2 are for connection of external loads. (Note prefuse!)

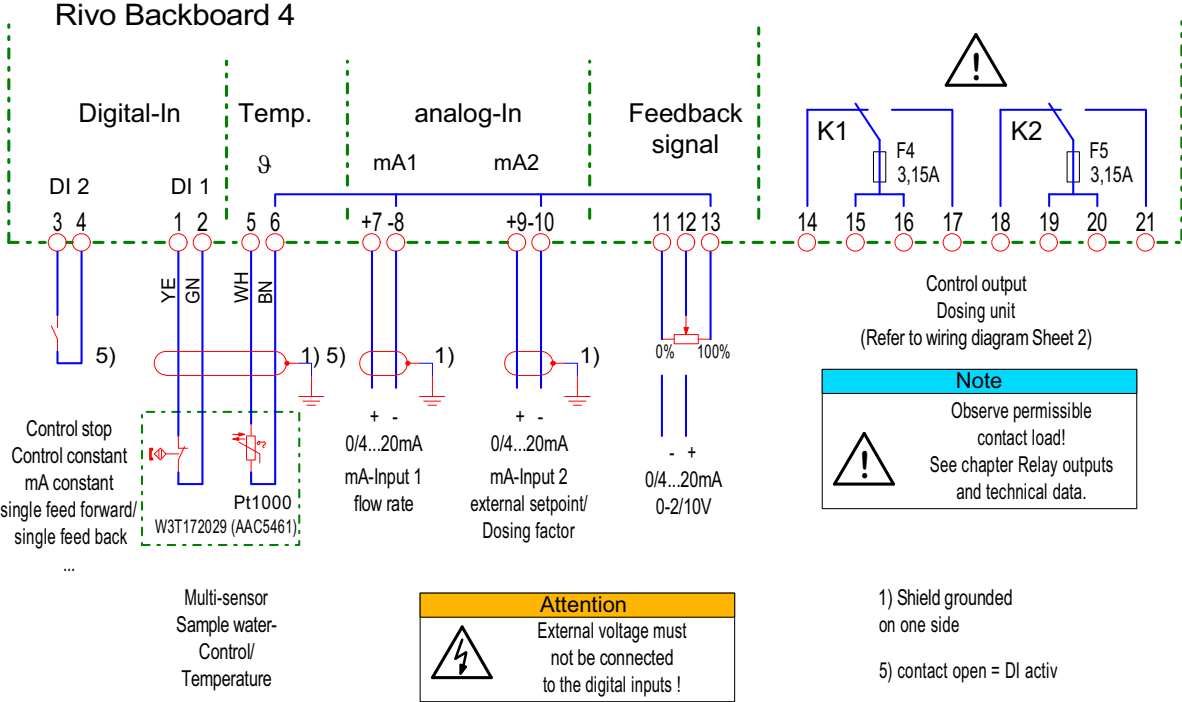

Measurement Channel I Controller outputs Backboard outputs Dosing

! Page 1 of 2

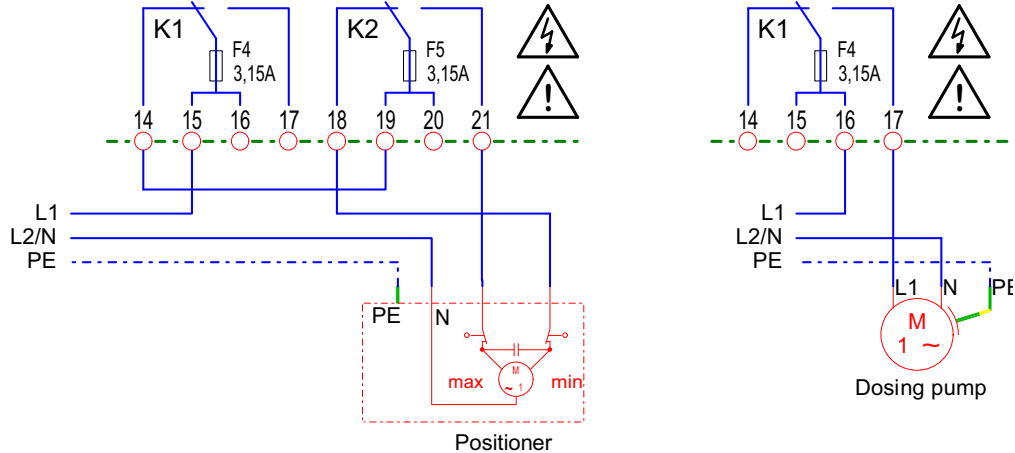

Attention
 External voltage may still be connected even when the main switch is set to OFF!

Note
 Observe permissible contact load!
 See chapter Relay outputs and technical data.

Measurement Channel I Controller outputs Backboard

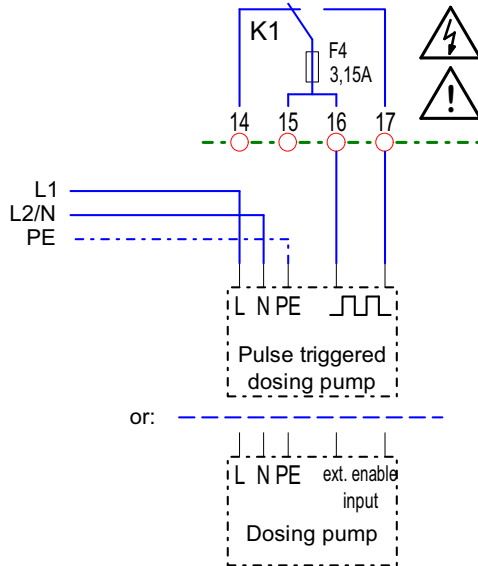

Attention

 External voltage may still be connected even when the main switch is set to OFF !

Note

 Observe permissible contact load! See chapter Relay outputs and technical data.

Connection (Sensor) - Measure module

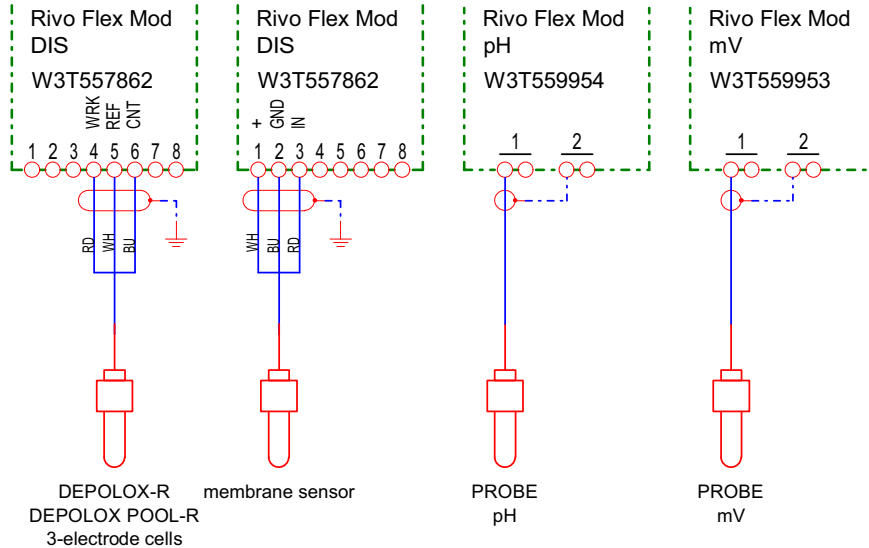

Connection (Sensor) - Measure module

 Page 2 of 4

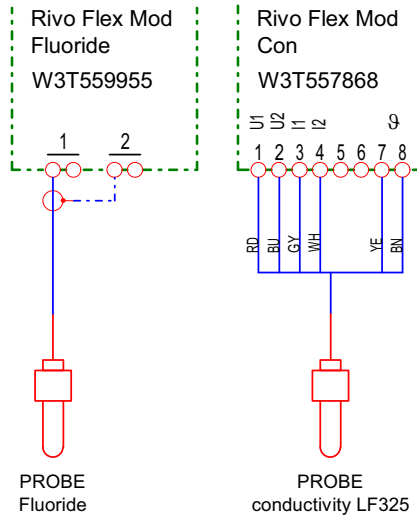

Connection (Sensor) - Measure module

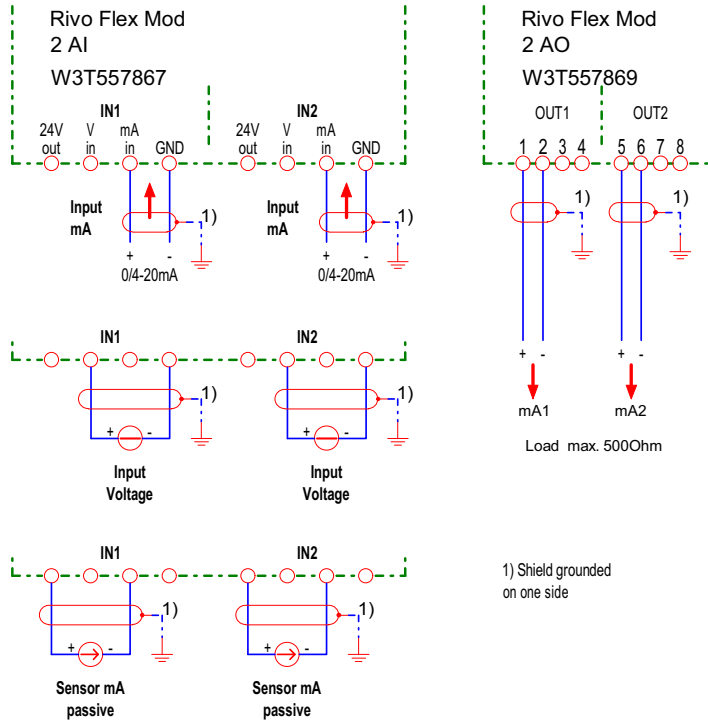

Connection (Sensor) - Measure module

! Page 4 of 4

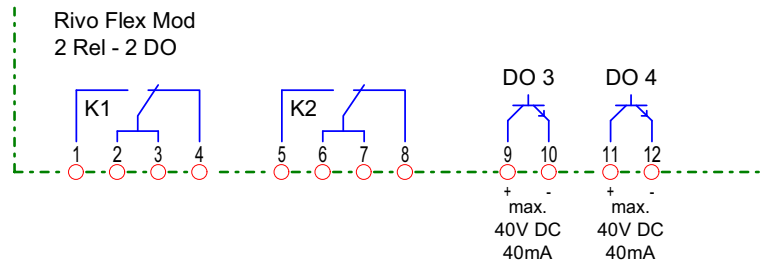

Measurement Channel II Controller outputs Mod. 3 (Rivo™ Flex Mod 2REL-2DO)

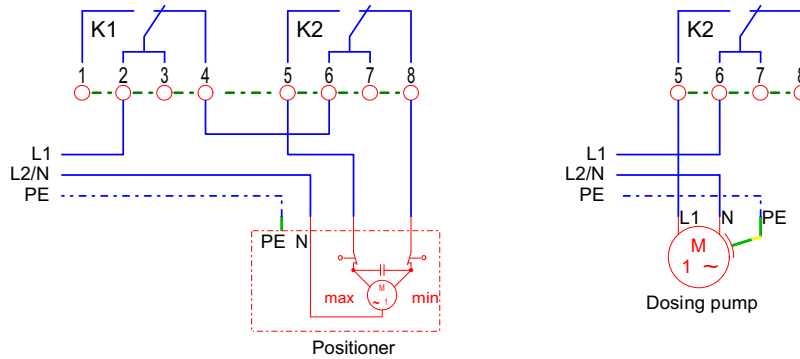

Attention
 External voltage may still be connected even when the main switch is set to OFF !

Note
 Observe permissible contact load!
 See chapter Relay outputs and technical data.

Measurement Channel II Controller outputs Mod. 3 (Rivo™ Flex Mod 2REL-2DO)

 Page 2 of 2

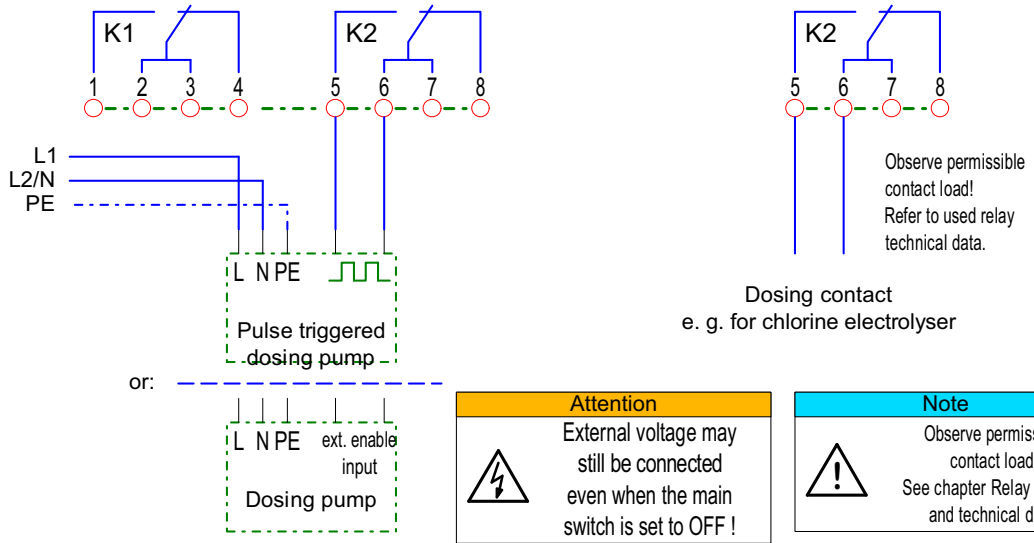

18 Wiring Diagram

EN Rivo™ I Municipal/Industrial

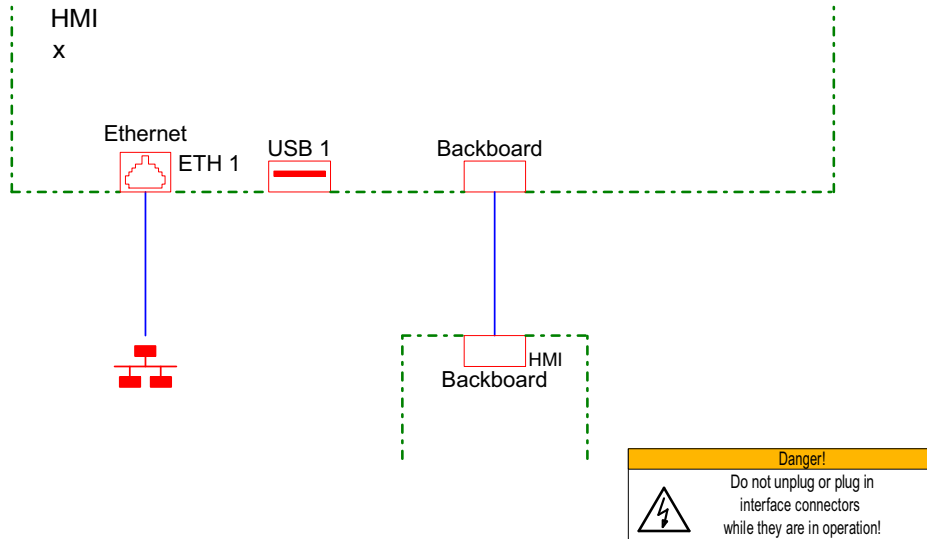

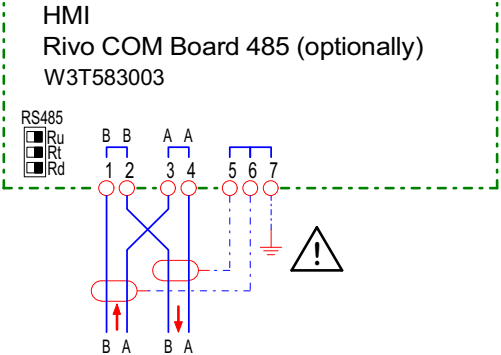

Note
Terminals 5 – 7 (no potential reference) for connecting the shielding establish. An additional PE connection at the start or end of the bus.

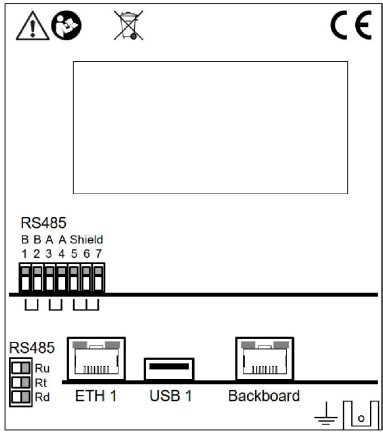

Danger!
Do not unplug or plug in interface connectors while they are in operation!

19 MARKING AND APPROVAL

19.1 CE mark

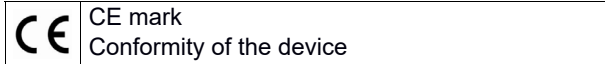

The Electronics Module Rivo™ I Municipal/Industrial (Mod. E10) meets the requirements of the harmonized European standards and thus complies with the statutory provisions of the EU directives. The manufacturer confirms successful testing of the device by affixing the CE mark.

The following harmonized European standards were applied:

- EMV/EMC: 2014/30/EU
- NRL/LVD: 2014/35/EU
- RoHS: 2011/65/EU and 2015/863/EU

19.2 UKCA mark

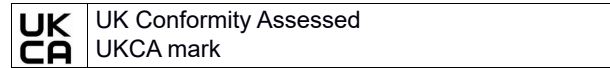

The electronic module Rivo™ I Municipal/Industrial (Mod. E10) meets the requirements of the harmonized European standards and thus complies with the statutory provisions of the EU directives. By affixing the UKCA mark, the manufacturer confirms that the device placed on the British market complies with the conformity requirements in Great Britain.

The following standards were applied:

- BS EN 61010-1:2010
- BS EN 61326-1:2021
- BS EN 63000:2018

20 LICENSE AGREEMENTS

The Electronics Module (Mod. E10) contains copy-right-protected software components covered by various Open Source licenses. Detailed information can be obtained from the Service-Center on the device.



Auf der Weide 10, 89312 Günzburg, Germany

+49 (0) 8221 9040

evoqua.com

© 2024 Evoqua Water Technologies GmbH

Subject to modifications

W3T613933 Issue 01-0624