

## Introducing Xylem’s A-Series Automatic Screen Filters

Xylem’s new VAF® A-Series automatic screen filters were designed specifically for the unique needs of agriculture and irrigation. The A-Series filters possess durable stainless steel designed to withstand the elements while also providing a balanced price point for agricultural customers. Another key feature is the filter’s remote capability, allowing the system to be battery- or solar-operated. This is crucial as rural agriculture locations and fields don’t always have easy access to electricity.



With the A-Series automatic screen filters, agriculture customers don’t have to sacrifice their irrigation and water needs for conservation.

Leveraging filters that provide the industry’s lowest flush volume, they can meet irrigation needs while also minimizing water usage. Patented technology powers the self-cleaning process. Over time, as particulates build up on the screens, automatic self-cleaning screen filters are triggered to remove suspended solids. Using internal water pressure, an innovative bi-directional screw is engaged to automatically clean the filter. As that water goes through the internal parts of the system, it creates a rotational direction that moves these vacuum nozzles around in a circle, and then the bi-directional screws allow it to move up and down vertically across the filter. These patented technologies are differentiators for the VAF line of filters. Unlike conventional alternatives, VAF filters do not require motors, pistons, or other high-cost equipment for effectively cleaning the filter element.

With minimal moving parts, the VAF A-Series automatic screen filters lower maintenance requirements, reduce operating costs, and are less prone to leakage due to fewer filter body penetrations of the stainless steel housing. Filters have a recommended routine maintenance schedule of 6-12 months, so they can operate with limited human interaction for extended time periods which reduces time spent monitoring irrigation equipment and allows for more time spent tending to valuable crops.

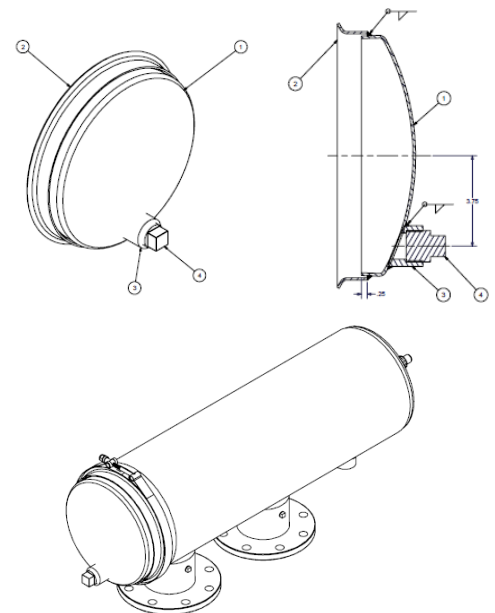

### A-Series Diagram

Item	Description
1	Tank End Cap
2	Ring, Marman Clap Lid
3	Lip Coupling
4	Tank Plug

The filter also includes a Marman clamp lid on the 250 and 500 gpm models to further improve ease of use, making it perfect for “on-the-go” cleaning or maintenance as required by the irrigation industry.



Solar control capabilities enable the A-Series to be used easily in a remote setting. Solar can be used for the most sustainable solution, while the battery option can still be used for indoor applications or locations with variable weather.

The A-Series filter can be designed and engineered for filtration efficiencies ranging from 10 to 1500 microns.

Proven to retain over 99% of process water (averaging less than 1% of water loss), the proprietary design aids in sustainability and enhanced water reuse, while virtually eliminating operational costs. Due to the VAF filter’s patented design, the filter continues to operate during the cleaning cycle, preventing the need to shut down filtration as is required with alternative filtration methods. Xylem’s VAF A-Series filter typically achieves 100% screen cleaning in 10-15 seconds.

Constructed with 304 grade stainless steel and lower total pressure specifications to reduce cost compared to 316 grade stainless steel filters designed for industrial systems, the A-Series filters are far more durable than high flow plastic models, yet retail at a reasonable price point. The VAF product line has a long history of American manufacturing and sourcing. Xylem issues a guarantee of BABA compliance for its automatic screen filters, everything from the filters and screens are compliant with the Build America Buy America Act. Customers can be assured that >55% of the total component and manufacturing costs are American sources while production takes place in a Michigan facility.

Xylem’s VAF A-Series automatic screen filters represent a significant advancement in agricultural irrigation, providing durable, low-maintenance solutions that are both cost-effective and environmentally conscious. By integrating patented technology that minimizes water usage while maximizing filtration efficiency, these filters are helping agriculture customers optimize their operations and contribute to sustainable water management practices.

## VAF automatic screen filters driving impact for customers

1

### Driving Reliable Filtration and Improved Water Efficiency in Commercial Farming

#### The challenge

An innovator in vertical farming, needed an irrigation system that matched its proprietary aeroponic technology, which uses up to 95% less water than traditional field farming. Given the customer’s focus on sustainability and water conservation, it was critical to deploy an irrigation system capable of delivering the highest levels water efficiency. With 550+ plant varieties, the system also required exceptional filtration to protect its equipment from solid contaminants, ensuring the longevity of its nutrient-rich feeding systems.

#### The solution

Xylem’s VAF automatic screen filters were selected for their superior filtration capabilities—filtering down to 10 microns—and easy assembly/disassembly for cleaning. The filters’ flush discharge is among the lowest available, resulting in less than 1% water waste.

#### The results

Xylem’s VAF filters, containing only 70 parts (100-200 fewer than competitors), required minimal maintenance and no reliance on electric motors, pistons, or gearboxes prone to breakage. This allowed the customer to perform maintenance in-house without requiring expensive and time-consuming outside assistance. Due to the success of the VAF filters at this facility, the indoor agriculture company is considering deploying filters at additional sites.

**Figure 1: Number of Parts Required by Automatic Screen Filter Type**

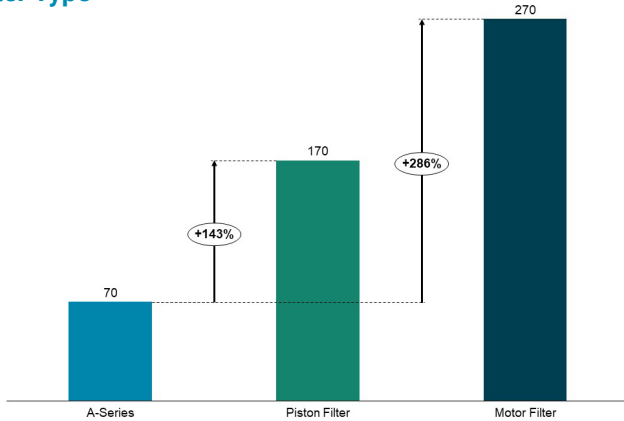

Containing 100-200 fewer parts than alternate filters, VAF filters require minimal maintenance reducing downtime for customers.

**2**

## Turf Irrigation Company Uses Battery-Controlled Filter to Drive Energy Efficiency at Remote Site

### The challenge

A turf irrigation company relied on a manual screen filter system that demanded frequent cleaning and maintenance, which was labor-intensive and inefficient. The system was unsuitable for their remote site where electricity was not readily available to power the irrigation and filtration systems.

### The solution

Xylem’s VAF automatic screen filters were selected for their ability to provide the required filter strength without reliance on a traditional power source. The filters’ automatic cleaning cycle does not require electricity, and the optional battery-operated controller further minimized the need for traditional power sources, making the system ideal for the turf irrigation company’s remote locations

### The results

The filter’s ease of maintenance, battery-powered operation, and self-cleaning feature have improved the efficiency and performance of the customer’s irrigation system, reducing labor costs and repair expenses while improving the quality of the turf. Additionally, the battery-operated configuration allowed the irrigation system to function reliably miles away from power sources and reduced the need for human intervention, with maintenance checks required only every 6 months.

Many automatic screen filters rely on small motors to operate their cleaning cycles, which limits their use in remote locations and increases energy consumption and operational costs. A single-phase 1 hp motor can cost over \$2 per day to run, potentially reaching \$700 annually for frequent cleaning needs. Even piston filters with electric control systems consume energy similar to a standard cable box, adding approximately \$75 per year in energy costs.

This innovation significantly lowered energy consumption and operational costs, eliminating the high energy costs associated with motor-driven or piston-operated filters, driving substantial savings and improved ROI for their filtration equipment. The ability to deploy VAF filters in remote locations set the VAF filters apart from other filtration systems, ultimately leading to the successful implementation of a more reliable and cost-effective irrigation system.

**3**

## Reducing Water Waste and Costly Maintenance at a San Diego Golf Course

### The challenge

A prestigious San Diego golf course faced significant challenges related to water use and waste given its location in a water scarce region. The course had been relying on a piston-driven automatic screen filter, which led to several inefficiencies:

- **High Water Waste:** The filter system required a high flush volume, resulting in considerable water waste, which conflicted with the golf course’s sustainability objectives.
- **Complex Operation:** The system’s operation was complicated, necessitating extensive training for new operators.
- **Time-Consuming Maintenance:** The complex design of the filter made maintenance difficult and time-consuming, causing delays in the course’s irrigation schedule and impacting the quality of the greens and fairways.

### The solution

To address these issues, the golf course opted to install Xylem’s VAF automatic screen filters to reduce water

waste and improve various efficiencies. With fewer moving parts and a simplified design, the VAF filter significantly reduced maintenance time and complexity, allowing for more consistent irrigation schedules. Additionally, the VAF filter was installed without requiring any modifications to the existing piping, saving the golf course from a costly reconfiguration. Beyond driving seamless integration and lower maintenance requirements, the VAF filter was also designed for user-friendly operation, reducing the need for extensive operator training.

**The results**

The VAF filter also contributed to significant operational expenditure (OPEX) savings of 30-60% and significant labor savings by reducing the need for screen and sprinkler head cleaning. The labor savings associated with mitigating screen change and cleaning associated with the battery-operated filter amounts to \$2,160-\$4,320 annually meanwhile labor savings associated with mitigating sprinkler head cleaning associated with the battery-operated filter amounts to \$4,320-\$8,640 annually.

**Figure 2: Size Comparison Between Standard Filters and VAF A-Series Filters**

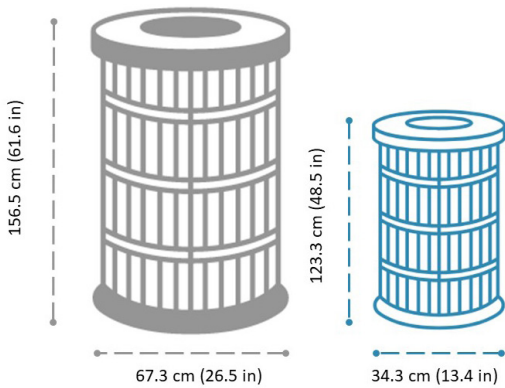

A reduced footprint allows A-Series filters to easily retrofit into either existing applications or new installs. Lowering capital expenses on additional piping and optimizing operations areas for easy maintenance.

Additionally, the golf course successfully met its sustainability goals by reducing water waste through the filter’s low flush volume of less than 1%. With its easy operation and low maintenance requirements, the course experienced fewer instances of system downtime, ensuring the maintenance of high-quality greens and fairways for its members.

**Figure 3: Opex Estimate Comparison Between Automated Screen Filter Types**

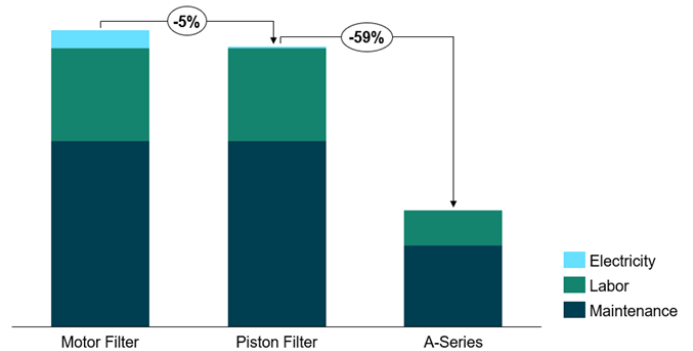

The A-Series automatic screen filters reduce operations expenses in addition to being less capital intensive. Savings can be seen in categories such as energy costs, labor, and equipment maintenance.

**Optimize your operations today.**

Xylem’s VAF A-Series automatic screen filters represent a significant advancement in agricultural irrigation, providing durable, low-maintenance solutions that are both cost-effective and environmentally conscious. By integrating patented technology that minimizes water usage while maximizing filtration efficiency, these filters are helping agriculture customers optimize their operations and contribute to sustainable water management practices.

[xylem.com](http://xylem.com)

All information presented herein is believed reliable and in accordance with accepted engineering practices. Xylem makes no warranties as to the completeness of this information. Users are responsible for evaluating individual product suitability for specific applications. Xylem assumes no liability whatsoever for any special, indirect or consequential damages arising from the sale, resale or misuse of its products. Subject to change without notice.

© 2024 Xylem Inc. or its affiliate. All rights reserved. VAF is a trademark of Xylem or one of its subsidiaries. XYLEM-VAF-IRRIGATIONSHOW-NEWPRODUCT

